

Produktbezeichnung/Product description	Seite/Page
UNIVERSAL-Messerköpfe / Profilmesser + Abweiser 40 mm EURO-System <i>UNIVERSAL head / profile blades + deflectors 40 mm EURO system</i>	6.2 - 6.3
Hartmetall MULTI PROFIL System 40 mm <i>Tungsten carbide MULTI PROFIL system 40 mm</i>	6.4
Profilübersicht für Profilmesser 40 mm EURO-System <i>Summary of mouldings for profiling blades 40 mm EURO system</i>	6.5 - 6.17
UNIVERSAL-Messerköpfe / Profilmesser + Abweiser 50 mm EURO-System <i>UNIVERSAL head / profile blades + deflectors 50 mm EURO system</i>	6.18
Hartmetall MULTI PROFIL System 50 mm <i>Tungsten carbide MULTI PROFIL system 50 mm</i>	6.19
UNIVERSAL-Profilmesser + Falzkopf 40/50 Z 2 <i>UNIVERSAL profiling and rebating head 40/50 Z 2</i>	6.20



UNIVERSAL-Messerköpfe und Profilmesser
Rückenverzahnte Profilmesserköpfe und Blanketts
UNIVERSAL heads and profiling blades
Serrated profile cutters and blanks

Profilübersicht für Profilmesser 50 mm EURO-System <i>Summary of mouldings for profiling blades 50 mm EURO system</i>	6.21 - 6.26
UNIVERSAL-Großprofiler-System 60/80 x 5,5 mm SP + HS <i>UNIVERSAL large profiler system 60/80 x 5,5 mm SP + HS</i>	6.27
Profilübersicht für Profilmesser Großprofiler-System 60 + 80 x 5,5 <i>Summary of mouldings for profiling blades of the large profiler system 60 + 80 x 5,5 mm</i> . . .	6.28 - 6.29
Profilmesserkopf RÜCKENVERZAHNT <i>Profile head SERRATED</i>	6.30
HS-Blanketten mit Rückenverzahnung <i>HS-Serrated cutter blanks</i>	6.31
Preisübersicht HS-Sonderprofile und Blanketts <i>Prices for HS-special profiles and blanks</i>	6.32
Preisübersicht Schärfpreise für UNI-Profilmesser und Sonderprofile <i>Prices of sharpening/UNI profiles and special profiles</i>	6.33

UNIVERSAL-Profilmesserkopf Z 2

für Profilmesser 40 x 4 mm - EURO-System -

UNIVERSAL head for profiling blades Z 2

EURO-System 40 x 4 mm



Ausführung:

Werkzeugkörper aus Stahl oder hochfestem Leichtmetall, spandickenbegrenzt, rückschlagarm, vorzugsweise für Handvorschubarbeiten.

Formschlüssige Messer- und Abweiserbefestigung auf konstanten Flugkreis.

Profilmesser aus **SP-Stahl und HS-Stahl** - seitlich hinterschliften - lieferbar!

Grundwerkzeug wird mit Falzmesser in SP-Stahl bestückt geliefert!

Max. Profiltiefe 17 mm

Design:

Universal head for profiling blades, chip-thickness limitation, reduced recoil, preferably for manual feed. Tool made from steel or light metal with high tensile strength. Positive blade and deflector fastening with constant cutting circle. Profiling blades with lateral set-off. Blades made from special steel and high speed steel.

Max. profile depth 17 mm



Art.-Nr./Item no. 3502

Anwendung:

Vorwiegend zum Profilieren von Weich- und Harthölzern (Vollholz unverleimt).

Profilmesser mit den jeweils zugeordneten Abweiserplatten sind stets paarweise einzusetzen.

Abb. der lieferbaren Profile siehe folgende Seiten.

Application:

Preferably for soft- and hardwood (unglued solid wood).

Profiling blades and the corresponding deflectors to be used in pairs.

Illustrations of the available profiles, see on following pages.



Art.-Nr./Item no. 3510

Artikel-Nr. Item no.	Abmessung mm Dimensions mm D/D B/W d/b	Ausführung Quality	Z	n/min ⁻¹	EURO Stück/pce
3500	93 x 40 x 30	Stahl/Steel	2	5.800 - 9.000	
3502	100 x 40 x 30	Leichtmetall/Light metal	2	5.800 - 9.000	
3503	120 x 40 x 30	Stahl/Steel	2	5.100 - 7.900	
3504	120 x 40 x 30	Leichtmetall/Light metal	2	5.100 - 7.900	

UNIVERSAL-Werkzeug-Sätze kompl.

best. aus Holzkassette, gefüllt mit: 1 Messerkopf mit Falzmesser bestückt sowie jeweils paarweise Profilmesser und Abweiser entsprechend nachstehenden Satz-Vorschlägen

(* bei Bestellung bitte angeben ob der Solokopf in Stahl- oder Leichtmetall-Ausführung geliefert werden soll.)

UNIVERSAL tool sets, complete

Consisting of wooden box containing 1 head equipped with rabbeting blade as well as profiling blades and deflectors (in pairs) as proposed below.

(* When ordering, please quote whether the "Solokopf" head shall be supplied in steel or in light metal.)

Artikel-Nr. Item no.	Abmessung mm Dimensions mm D/D B/W d/b	Ausführung Quality	EURO Stück/pce
3506	100 x 40 x 30*	UNI-SET m. 6 Profilen Nr. 1, 5, 19, 20, 26, 36/UNI-SET with 6 profiles no. 1, 5, 19, 20, 26, 36	
3507	100 x 40 x 30*	UNI-SET m. 6 Profilen Nr. 1 - 6/UNI-SET with 6 profiles no. 1 - 6	
3510	100 x 40 x 30*	UNI-SET m. 10 Profilen Nr. 1 - 10/UNI-SET with 10 profiles no. 1 - 10	
3520	100 x 40 x 30*	UNI-SET m. 20 Profilen Nr. 1 - 20/UNI-SET with 20 profiles no. 1 - 20	
3530	100 x 40 x 30*	UNI-SET m. 30 Profilen Nr. 1 - 30/UNI-SET with 30 profiles no. 1 - 30	
3551		Holzkassette für 6 Profilsätze, leer/Wooden box for 6 profile sets, empty	
3552		Holzkassette für 12 Profilsätze, leer/Wooden box for 12 profile sets, empty	
3555		Holzkassette für 24 Profilsätze, leer/Wooden box for 24 profile sets, empty	

Profilmesser und Abweiser (Abgabe ausschließlich paarweise) Profiling blades and deflectors (only in pairs)

Artikel-Nr. Item no.	Bezeichnung Description	Profil-Nr. Profil no.	EURO Stück/pce
-------------------------	----------------------------	--------------------------	-------------------

SP-Stahl-Ausführung/Special steel design

3600 - 36135	UNI-Profilmesser 40 x 4 mm/UNI profiling blade 40 x 4 mm	0 - 135	
36136 - 36177	UNI-Profilmesser 40 x 4 mm/UNI profiling blade 40 x 4 mm	136 - 177	

HS-Ausführung/High speed steel design

36300 - 36393	UNI-Profilmesser 40 x 4 mm/UNI profiling blade 40 x 4 mm	0 - 93	
36394 - 36397	UNI-Profilmesser 40 x 4 mm - Konterprofile 1 - 4/UNI counter profile 1 - 4 - 40 x 4 mm	94 - 97	
36398 - 36400	UNI-Profilmesser 40 x 4 mm - Abplattprofil/UNI counter flattening blade 40 x 4 mm	98 - 100	
36401 - 36435	UNI-Profilmesser 40 x 4 mm/UNI profiling blade 40 x 4 mm	101 - 135	
36436 - 36477	UNI-Profilmesser 40 x 4 mm/UNI profiling blade 40 x 4 mm	136 - 177	

Abweiser/Deflectors

3700 - 37135	Abweiser 38 mm/Deflectors 38 mm	0 - 135	
37136 - 37177	Abweiser 38 mm/Deflectors 38 mm	136 - 177	

Weitere Ersatzteile (Schrauben, Spannkeile usw.) siehe Seite 14.5 - 14.9
More Replacement parts (screws, wedges etc.) see page 14.5 - 14.9

Blanketts für UNI-Profilmesser Blanks for UNI-profiling blades

Artikel-Nr. Item no.	Bezeichnung Description	A mm	B mm	EURO Stück/pce
36900	Blankett 40 x 4 mm - HS/Blank 40 x 4 mm high-speed steel	32,5	40	
36901	Blankett 40 x 4 mm - SP/Blank 40 x 4 mm special steel	32,5	40	
37999	Blankett 38 x 4 mm - Abweiser/Blank 38 x 4 mm - deflector	31,5	38	

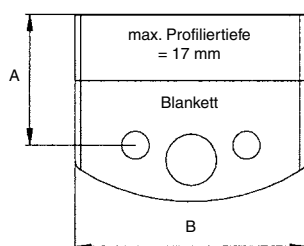

- Sonderprofile nach Zeichnung oder Holzmuster - auf Anfrage!
● Special profiles to drawing or sample upon request!
- Sonderprofil - Preisgruppen siehe Seite 6.33
● Price categories applicable to special profiles: please see page 6.33
- Schärfpriese für Standard- und Sonderprofile siehe Seite 6.33
● Price of sharpening/standard and special profiles: please see page 6.33
- Abgabe der Standard- und Sonderprofile immer satzweise
● All standard and special profiles only available in pairs

NEU

Alle Standard-Profile und Sonder-Profile
40 + 50 mm ab sofort auch in
HARTMETALL (HW)-Qualität
als MULTI-PROFIL-System lieferbar!

Preise und Details siehe Seiten 6.4 + 6.19

NEW

All standard-profiles and special-profiles
40 + 50 mm also available as
MULTI-PROFIL-System in
TUNGSTEN-CARBIDE (TC)-quality

Prices and details
please see pages 6.4 + 6.19

MULTI-PROFIL System

40 mm („EURO-System“-kompatibel) 40 mm (compatible with EURO-system)



Ausführung:

Das **MULTI-PROFIL**-Messer-System besteht aus jeweils profilierter Trägerplatte + profilierter Schneidplatte (HW-Qualität) + profilierter Abweiserplatte.

Achtung: lt. BG-Vorschrift erfolgt Abgabe stets satzweise bzw. paarweise!!

Das System ist im eingebauten Zustand form- und kraftschlüssig, rückschlagarm, in Verbindung mit Abweiserplatten für Handvorschubarbeiten, ansonsten jedoch auch für mech. Vorschub und CNC-Einsatz geeignet.

Alle Schneidplatten sind grundsätzlich seitlich hinterschleifen!

Das Messer-System passt ohne Änderungen in alle handelsübliche UNI-Profil-Messerköpfe „Euro-System“!

Anwendung:

Vorwiegend zum Profilieren von Abrasivstoffen wie Corian, MDF, Multiplex und anderen Verbundstoffen/Leimhölzern geeignet.

Abbildungen der lieferbaren Profile siehe BRÜCK-Katalog Produktgruppe 6; Seiten 6.5 - 6.17

Design:

The **MULTI-PROFILING** system consists of a profiled blade holder + profiled blade (TC) each.

Attention: Blades and deflectors have to be used in pairs !!

This system has a form- and force-locked tension, reduced recoil, in combination with deflectors preferably for manual feed. Otherwise also usable for mec. feed and operation on CNC machines.

All blades have a laterally relief-ground.

This system is usable for all customary UNIVERSAL cutter heads, „EURO-system“, without any changes.

Application:

Mainly used for profiling abrasive materials like Corian, MDF, Multiplex, other boards or glued woods.

Pictures of all available profiles are shown in our catalogue product group 6, page 6.5 - 6.17

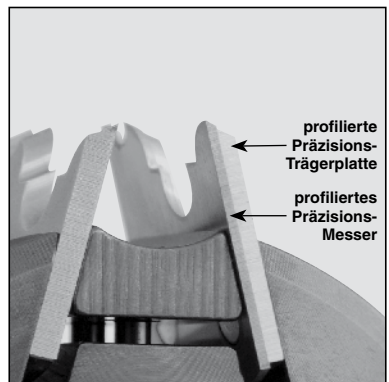
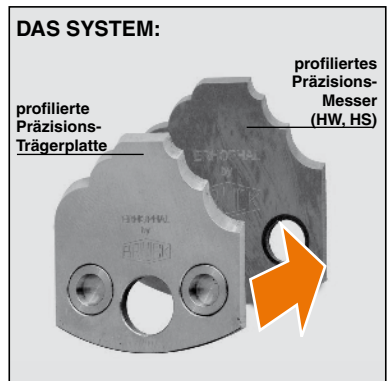

Standardprofile/Standard Profiles

Artikel-Nr. Item no.	Bezeichnung Description	Profil-Nr. profile no.	EURO Stück/pce
35000HW - 35131HW	Profil-Messer HW-Qualität/profiling blade TC-quality	0 - 131	
37000TP - 37131TP	Profil-Trägerplatten/profile blade holder	0 - 131	
3700 - 37131	Profil-Abweiser/profile deflector	0 - 131	
35000HWS - 35131HWS	Kompl. HW-Profilmessersatz best. aus: 2 Messern, 2 Trägerplatten und 2 Abweisern Complete TC-profile blade set consists of: 2 blades, 2 blade holders and 2 deflectors	0 - 131	

Blanketts/Blanks

35900HWS	HW-Messersatz-Blanketts/TC-blade set blanks (je 2x Messer & Trägerplatten)/(2x blades & blade holder each)		
----------	--	--	--

Sonderprofile/Special Profiles

Profilgruppe profile category	Artikel-Nr./Item no. HW-Qualität/TC-quality	EURO Stück/pce HW/TC
A) kompl. Satz bestehend aus: jeweils 2 Messern, 2 Trägerplatten und 2 Abweisern A) complete set consists of: 2 blades, 2 blade holders and 2 deflectors each		
1	35001HWS-SO	
2	35002HWS-SO	
3	35003HWS-SO	
B) Nachbestellung pro Paar Ersatzmesser B) repeat order/price for one pair replacement blades		
1	35001HW-SO	
2	35002HW-SO	
3	35003HW-SO	

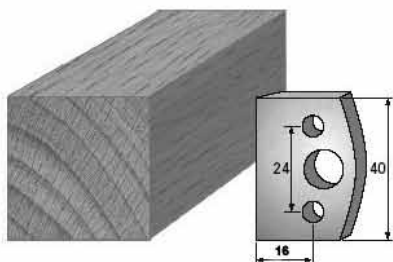

SP-Messer/Blade = Art.-Nr./Item no. 36000
HS-Messer/Blade = Art.-Nr./Item no. 36298
Abweiser/Deflector = Art.-Nr./Item no. 37000

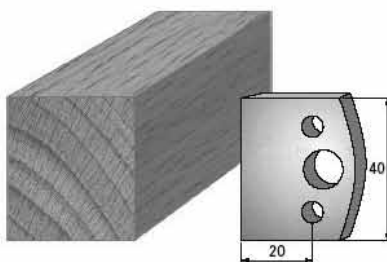

SP-Messer/Blade = Art.-Nr./Item no. 3600
HS-Messer/Blade = Art.-Nr./Item no. 36300
Abweiser/Deflector = Art.-Nr./Item no. 3700

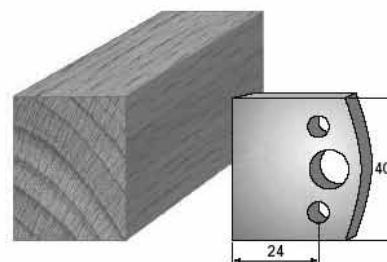

SP-Messer/Blade = Art.-Nr./Item no. 36001
HS-Messer/Blade = Art.-Nr./Item no. 36299
Abweiser/Deflector = Art.-Nr./Item no. 37001

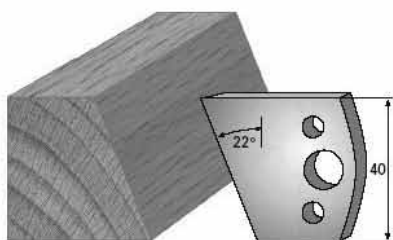

SP-Messer/Blade = Art.-Nr./Item no. 3601
HS-Messer/Blade = Art.-Nr./Item no. 36301
Abweiser/Deflector = Art.-Nr./Item no. 3701

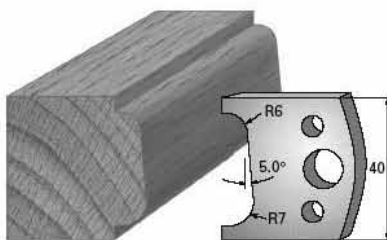

SP-Messer/Blade = Art.-Nr./Item no. 3602
HS-Messer/Blade = Art.-Nr./Item no. 36302
Abweiser/Deflector = Art.-Nr./Item no. 3702

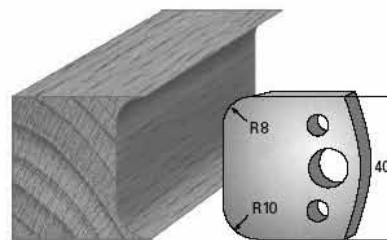

SP-Messer/Blade = Art.-Nr./Item no. 3603
HS-Messer/Blade = Art.-Nr./Item no. 36303
Abweiser/Deflector = Art.-Nr./Item no. 3703

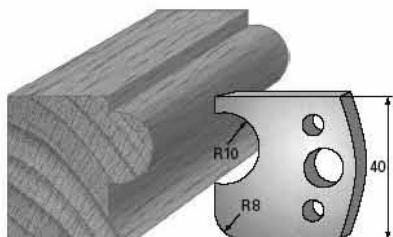

SP-Messer/Blade = Art.-Nr./Item no. 3604
HS-Messer/Blade = Art.-Nr./Item no. 36304
Abweiser/Deflector = Art.-Nr./Item no. 3704

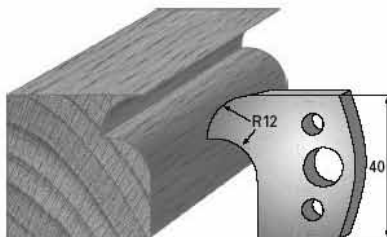

SP-Messer/Blade = Art.-Nr./Item no. 3605
HS-Messer/Blade = Art.-Nr./Item no. 36305
Abweiser/Deflector = Art.-Nr./Item no. 3705

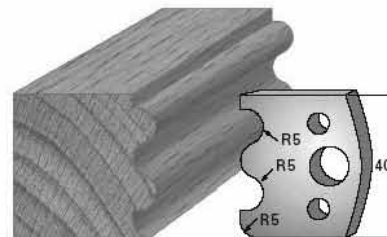

SP-Messer/Blade = Art.-Nr./Item no. 3606
HS-Messer/Blade = Art.-Nr./Item no. 36306
Abweiser/Deflector = Art.-Nr./Item no. 3706

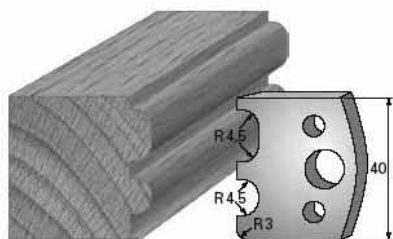

SP-Messer/Blade = Art.-Nr./Item no. 3607
HS-Messer/Blade = Art.-Nr./Item no. 36307
Abweiser/Deflector = Art.-Nr./Item no. 3707

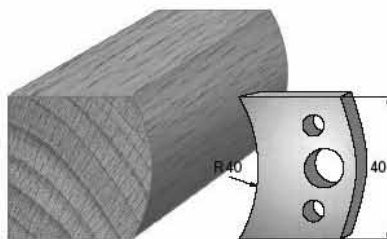

SP-Messer/Blade = Art.-Nr./Item no. 3608
HS-Messer/Blade = Art.-Nr./Item no. 36308
Abweiser/Deflector = Art.-Nr./Item no. 3708

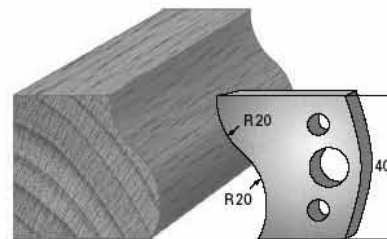

SP-Messer/Blade = Art.-Nr./Item no. 3609
HS-Messer/Blade = Art.-Nr./Item no. 36309
Abweiser/Deflector = Art.-Nr./Item no. 3709

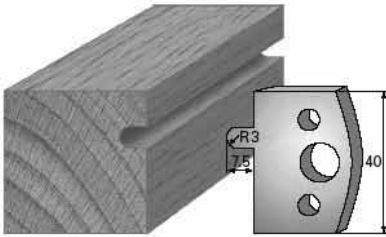

SP-Messer/Blade = Art.-Nr./Item no. 3610
 HS-Messer/Blade = Art.-Nr./Item no. 36310
 Abweiser/Deflector = Art.-Nr./Item no. 3710

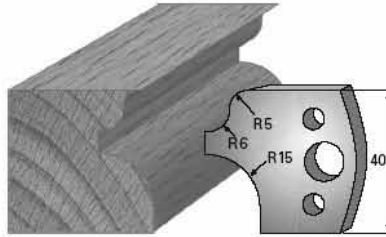

SP-Messer/Blade = Art.-Nr./Item no. 3611
 HS-Messer/Blade = Art.-Nr./Item no. 36311
 Abweiser/Deflector = Art.-Nr./Item no. 3711

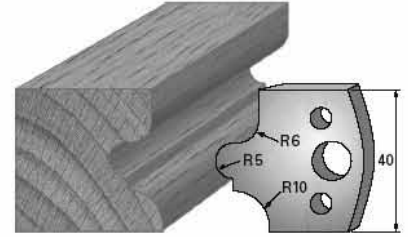

SP-Messer/Blade = Art.-Nr./Item no. 3612
 HS-Messer/Blade = Art.-Nr./Item no. 36312
 Abweiser/Deflector = Art.-Nr./Item no. 3712

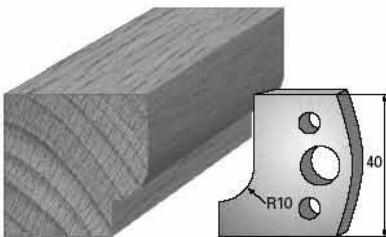

SP-Messer/Blade = Art.-Nr./Item no. 3613
 HS-Messer/Blade = Art.-Nr./Item no. 36313
 Abweiser/Deflector = Art.-Nr./Item no. 3713

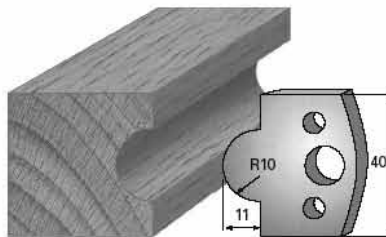

SP-Messer/Blade = Art.-Nr./Item no. 3614
 HS-Messer/Blade = Art.-Nr./Item no. 36314
 Abweiser/Deflector = Art.-Nr./Item no. 3714

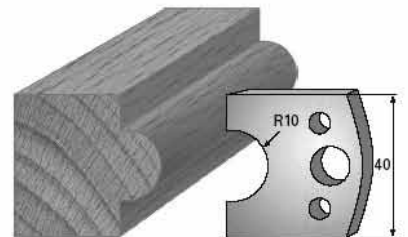

SP-Messer/Blade = Art.-Nr./Item no. 3615
 HS-Messer/Blade = Art.-Nr./Item no. 36315
 Abweiser/Deflector = Art.-Nr./Item no. 3715

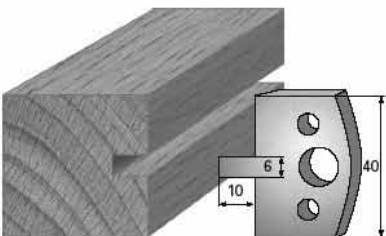

SP-Messer/Blade = Art.-Nr./Item no. 3616
 HS-Messer/Blade = Art.-Nr./Item no. 36316
 Abweiser/Deflector = Art.-Nr./Item no. 3716

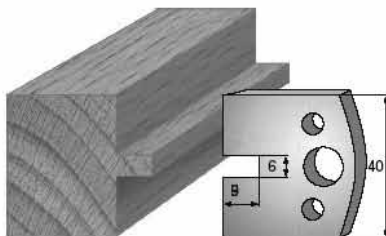

SP-Messer/Blade = Art.-Nr./Item no. 3617
 HS-Messer/Blade = Art.-Nr./Item no. 36317
 Abweiser/Deflector = Art.-Nr./Item no. 3717

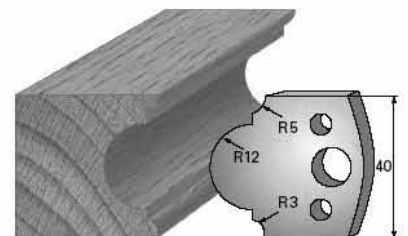

SP-Messer/Blade = Art.-Nr./Item no. 3618
 HS-Messer/Blade = Art.-Nr./Item no. 36318
 Abweiser/Deflector = Art.-Nr./Item no. 3718

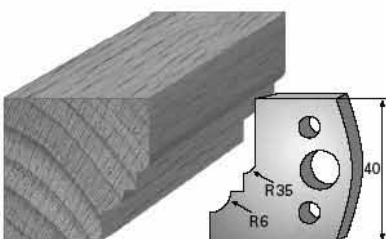

SP-Messer/Blade = Art.-Nr./Item no. 3619
 HS-Messer/Blade = Art.-Nr./Item no. 36319
 Abweiser/Deflector = Art.-Nr./Item no. 3719

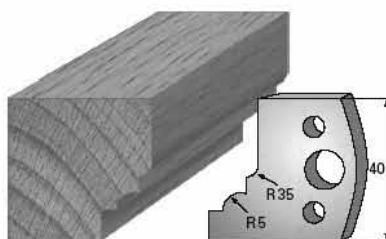

SP-Messer/Blade = Art.-Nr./Item no. 3620
 HS-Messer/Blade = Art.-Nr./Item no. 36320
 Abweiser/Deflector = Art.-Nr./Item no. 3720

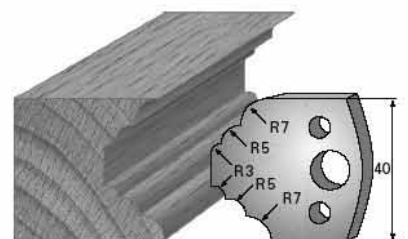

SP-Messer/Blade = Art.-Nr./Item no. 3621
 HS-Messer/Blade = Art.-Nr./Item no. 36321
 Abweiser/Deflector = Art.-Nr./Item no. 3721

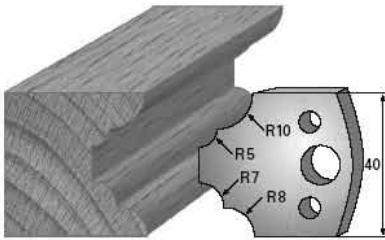

SP-Messer/Blade = Art.-Nr./Item no. 3622
HS-Messer/Blade = Art.-Nr./Item no. 36322
Abweiser/Deflector = Art.-Nr./Item no. 3722

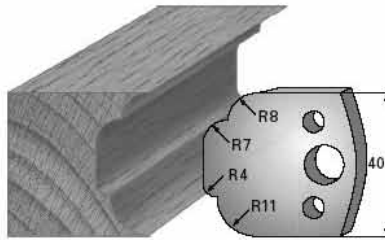

SP-Messer/Blade = Art.-Nr./Item no. 3623
HS-Messer/Blade = Art.-Nr./Item no. 36323
Abweiser/Deflector = Art.-Nr./Item no. 3723

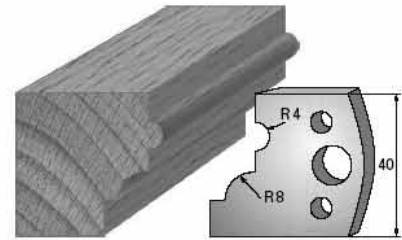

SP-Messer/Blade = Art.-Nr./Item no. 3624
HS-Messer/Blade = Art.-Nr./Item no. 36324
Abweiser/Deflector = Art.-Nr./Item no. 3724

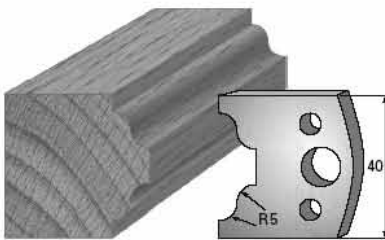

SP-Messer/Blade = Art.-Nr./Item no. 3625
HS-Messer/Blade = Art.-Nr./Item no. 36325
Abweiser/Deflector = Art.-Nr./Item no. 3725

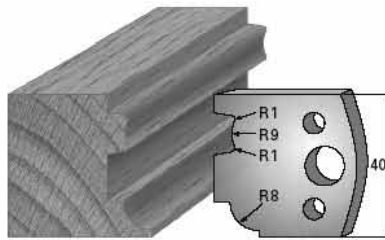

SP-Messer/Blade = Art.-Nr./Item no. 3626
HS-Messer/Blade = Art.-Nr./Item no. 36326
Abweiser/Deflector = Art.-Nr./Item no. 3726

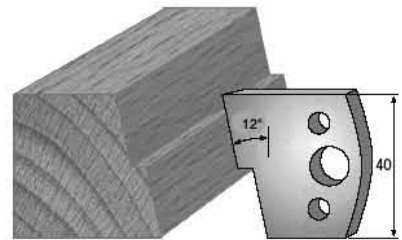

SP-Messer/Blade = Art.-Nr./Item no. 3627
HS-Messer/Blade = Art.-Nr./Item no. 36327
Abweiser/Deflector = Art.-Nr./Item no. 3727

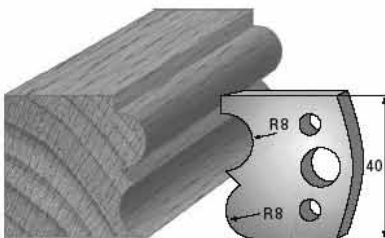

SP-Messer/Blade = Art.-Nr./Item no. 3628
HS-Messer/Blade = Art.-Nr./Item no. 36328
Abweiser/Deflector = Art.-Nr./Item no. 3728

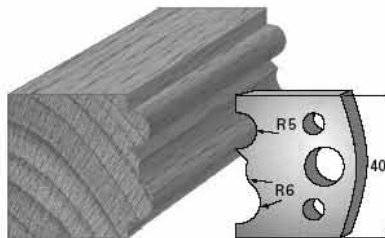

SP-Messer/Blade = Art.-Nr./Item no. 3629
HS-Messer/Blade = Art.-Nr./Item no. 36329
Abweiser/Deflector = Art.-Nr./Item no. 3729

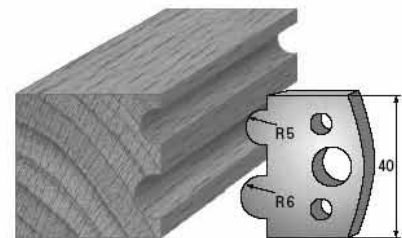

SP-Messer/Blade = Art.-Nr./Item no. 3630
HS-Messer/Blade = Art.-Nr./Item no. 36330
Abweiser/Deflector = Art.-Nr./Item no. 3730

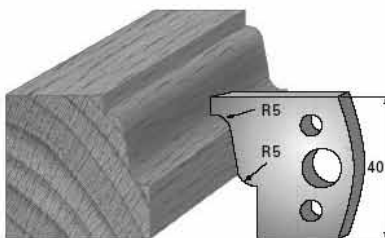

SP-Messer/Blade = Art.-Nr./Item no. 3631
HS-Messer/Blade = Art.-Nr./Item no. 36331
Abweiser/Deflector = Art.-Nr./Item no. 3731

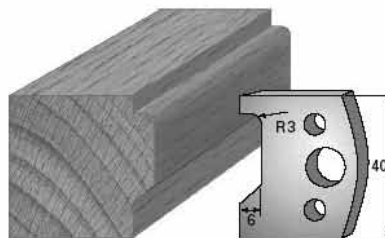

SP-Messer/Blade = Art.-Nr./Item no. 3632
HS-Messer/Blade = Art.-Nr./Item no. 36332
Abweiser/Deflector = Art.-Nr./Item no. 3732

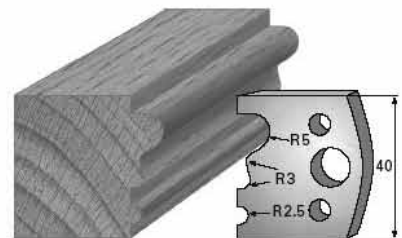

SP-Messer/Blade = Art.-Nr./Item no. 3633
HS-Messer/Blade = Art.-Nr./Item no. 36333
Abweiser/Deflector = Art.-Nr./Item no. 3733

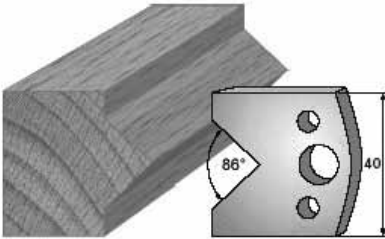

SP-Messer/Blade = Art.-Nr./Item no. 3634
HS-Messer/Blade = Art.-Nr./Item no. 36334
Abweiser/Deflector = Art.-Nr./Item no. 3734

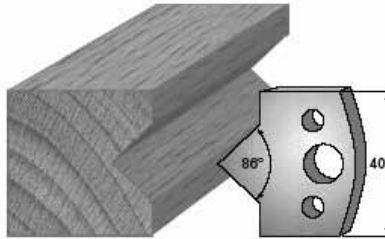

SP-Messer/Blade = Art.-Nr./Item no. 3635
HS-Messer/Blade = Art.-Nr./Item no. 36335
Abweiser/Deflector = Art.-Nr./Item no. 3735

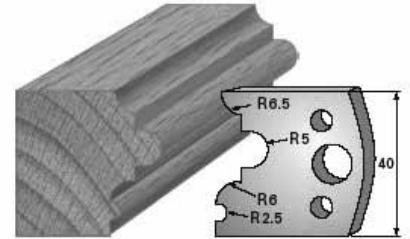

SP-Messer/Blade = Art.-Nr./Item no. 3636
HS-Messer/Blade = Art.-Nr./Item no. 36336
Abweiser/Deflector = Art.-Nr./Item no. 3736

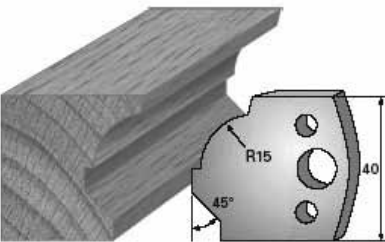

SP-Messer/Blade = Art.-Nr./Item no. 3637
HS-Messer/Blade = Art.-Nr./Item no. 36337
Abweiser/Deflector = Art.-Nr./Item no. 3737

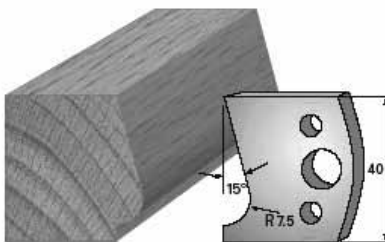

SP-Messer/Blade = Art.-Nr./Item no. 3638
HS-Messer/Blade = Art.-Nr./Item no. 36338
Abweiser/Deflector = Art.-Nr./Item no. 3738

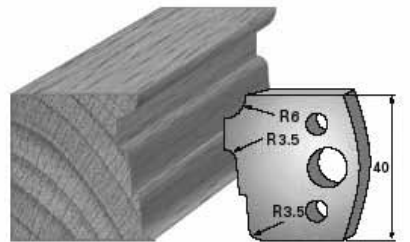

SP-Messer/Blade = Art.-Nr./Item no. 3639
HS-Messer/Blade = Art.-Nr./Item no. 36339
Abweiser/Deflector = Art.-Nr./Item no. 3739

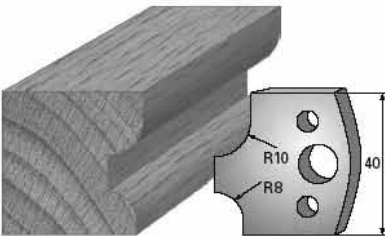

SP-Messer/Blade = Art.-Nr./Item no. 3640
HS-Messer/Blade = Art.-Nr./Item no. 36340
Abweiser/Deflector = Art.-Nr./Item no. 3740

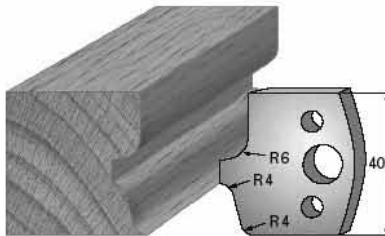

SP-Messer/Blade = Art.-Nr./Item no. 3641
HS-Messer/Blade = Art.-Nr./Item no. 36341
Abweiser/Deflector = Art.-Nr./Item no. 3741

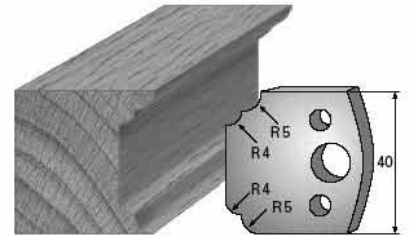

SP-Messer/Blade = Art.-Nr./Item no. 3642
HS-Messer/Blade = Art.-Nr./Item no. 36342
Abweiser/Deflector = Art.-Nr./Item no. 3742

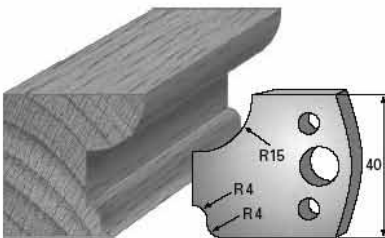

SP-Messer/Blade = Art.-Nr./Item no. 3643
HS-Messer/Blade = Art.-Nr./Item no. 36343
Abweiser/Deflector = Art.-Nr./Item no. 3743

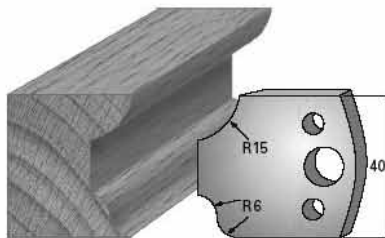

SP-Messer/Blade = Art.-Nr./Item no. 3644
HS-Messer/Blade = Art.-Nr./Item no. 36344
Abweiser/Deflector = Art.-Nr./Item no. 3744

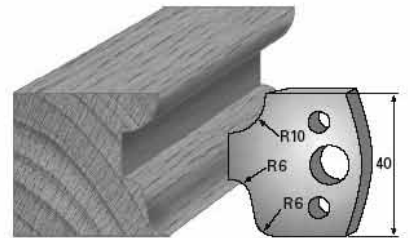

SP-Messer/Blade = Art.-Nr./Item no. 3645
HS-Messer/Blade = Art.-Nr./Item no. 36345
Abweiser/Deflector = Art.-Nr./Item no. 3745

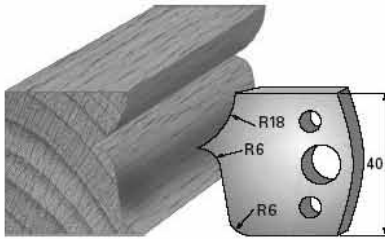

SP-Messer/Blade = Art.-Nr./Item no. 3646
HS-Messer/Blade = Art.-Nr./Item no. 36346
Abweiser/Deflector = Art.-Nr./Item no. 3746

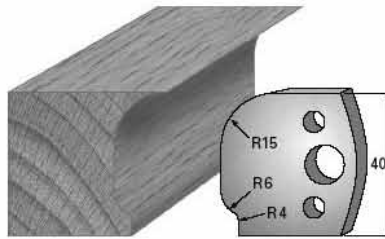

SP-Messer/Blade = Art.-Nr./Item no. 3647
HS-Messer/Blade = Art.-Nr./Item no. 36347
Abweiser/Deflector = Art.-Nr./Item no. 3747

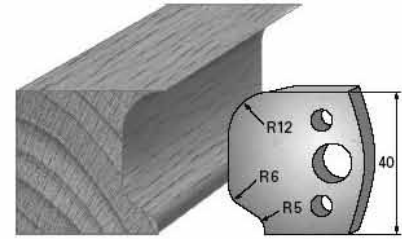

SP-Messer/Blade = Art.-Nr./Item no. 3648
HS-Messer/Blade = Art.-Nr./Item no. 36348
Abweiser/Deflector = Art.-Nr./Item no. 3748

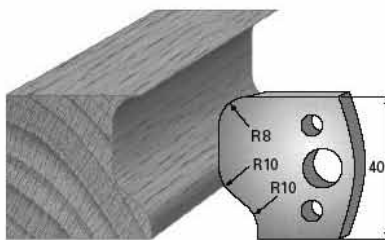

SP-Messer/Blade = Art.-Nr./Item no. 3649
HS-Messer/Blade = Art.-Nr./Item no. 36349
Abweiser/Deflector = Art.-Nr./Item no. 3749

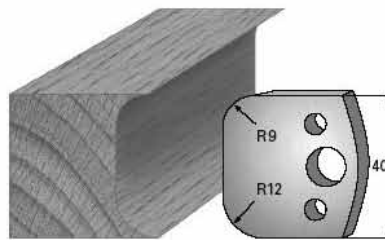

SP-Messer/Blade = Art.-Nr./Item no. 3650
HS-Messer/Blade = Art.-Nr./Item no. 36350
Abweiser/Deflector = Art.-Nr./Item no. 3750

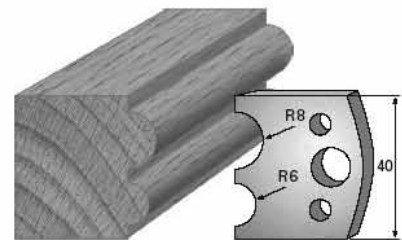

SP-Messer/Blade = Art.-Nr./Item no. 3651
HS-Messer/Blade = Art.-Nr./Item no. 36351
Abweiser/Deflector = Art.-Nr./Item no. 3751

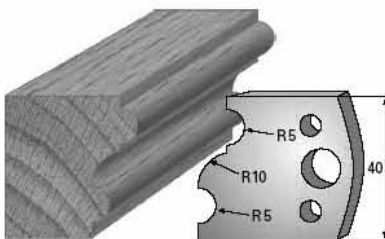

SP-Messer/Blade = Art.-Nr./Item no. 3652
HS-Messer/Blade = Art.-Nr./Item no. 36352
Abweiser/Deflector = Art.-Nr./Item no. 3752

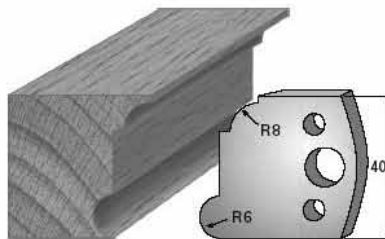

SP-Messer/Blade = Art.-Nr./Item no. 3653
HS-Messer/Blade = Art.-Nr./Item no. 36353
Abweiser/Deflector = Art.-Nr./Item no. 3753

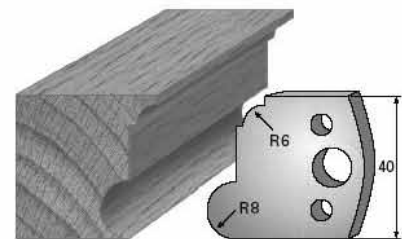

SP-Messer/Blade = Art.-Nr./Item no. 3654
HS-Messer/Blade = Art.-Nr./Item no. 36354
Abweiser/Deflector = Art.-Nr./Item no. 3754

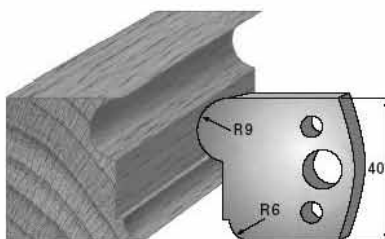

SP-Messer/Blade = Art.-Nr./Item no. 3655
HS-Messer/Blade = Art.-Nr./Item no. 36355
Abweiser/Deflector = Art.-Nr./Item no. 3755

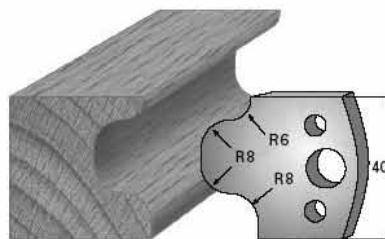

SP-Messer/Blade = Art.-Nr./Item no. 3656
HS-Messer/Blade = Art.-Nr./Item no. 36356
Abweiser/Deflector = Art.-Nr./Item no. 3756

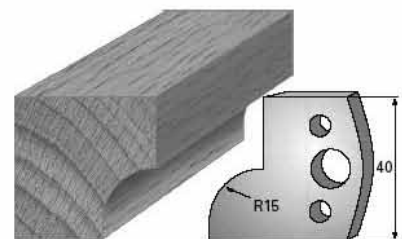

SP-Messer/Blade = Art.-Nr./Item no. 3657
HS-Messer/Blade = Art.-Nr./Item no. 36357
Abweiser/Deflector = Art.-Nr./Item no. 3757

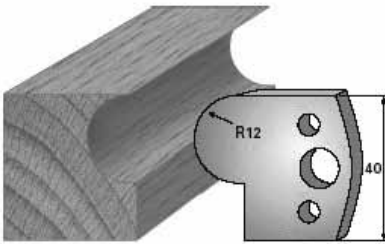

SP-Messer/Blade = Art.-Nr./Item no. 3658
 HS-Messer/Blade = Art.-Nr./Item no. 36358
 Abweiser/Deflector = Art.-Nr./Item no. 3758

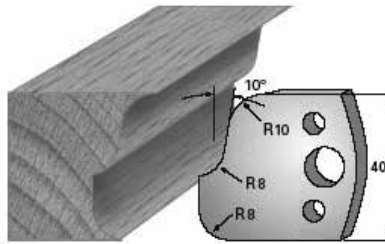

SP-Messer/Blade = Art.-Nr./Item no. 3659
 HS-Messer/Blade = Art.-Nr./Item no. 36359
 Abweiser/Deflector = Art.-Nr./Item no. 3759

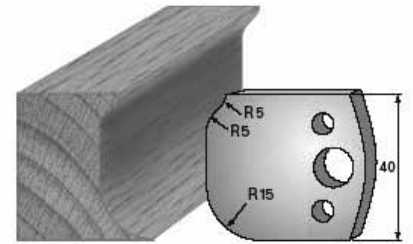

SP-Messer/Blade = Art.-Nr./Item no. 3660
 HS-Messer/Blade = Art.-Nr./Item no. 36360
 Abweiser/Deflector = Art.-Nr./Item no. 3760

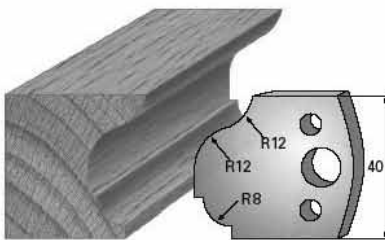

SP-Messer/Blade = Art.-Nr./Item no. 3661
 HS-Messer/Blade = Art.-Nr./Item no. 36361
 Abweiser/Deflector = Art.-Nr./Item no. 3761

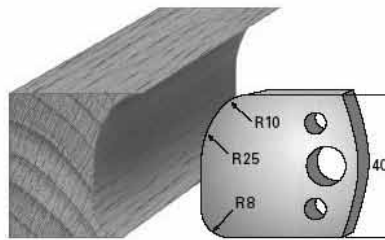

SP-Messer/Blade = Art.-Nr./Item no. 3662
 HS-Messer/Blade = Art.-Nr./Item no. 36362
 Abweiser/Deflector = Art.-Nr./Item no. 3762

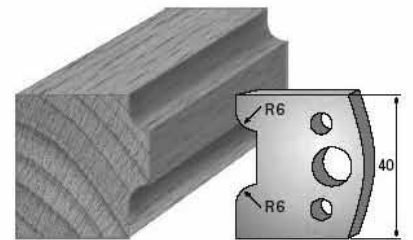

SP-Messer/Blade = Art.-Nr./Item no. 3663
 HS-Messer/Blade = Art.-Nr./Item no. 36363
 Abweiser/Deflector = Art.-Nr./Item no. 3763

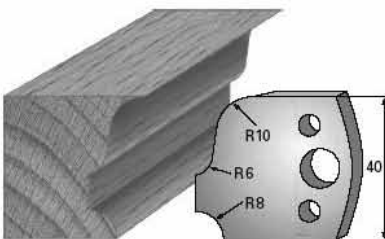

SP-Messer/Blade = Art.-Nr./Item no. 3664
 HS-Messer/Blade = Art.-Nr./Item no. 36364
 Abweiser/Deflector = Art.-Nr./Item no. 3764

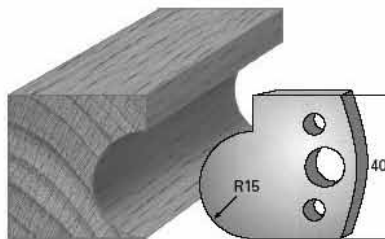

SP-Messer/Blade = Art.-Nr./Item no. 3665
 HS-Messer/Blade = Art.-Nr./Item no. 36365
 Abweiser/Deflector = Art.-Nr./Item no. 3765

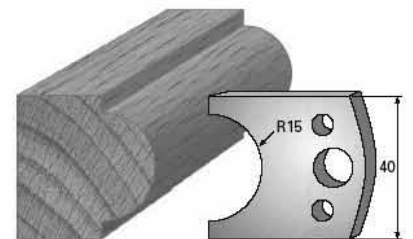

SP-Messer/Blade = Art.-Nr./Item no. 3666
 HS-Messer/Blade = Art.-Nr./Item no. 36366
 Abweiser/Deflector = Art.-Nr./Item no. 3766

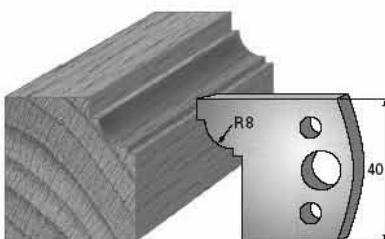

SP-Messer/Blade = Art.-Nr./Item no. 3667
 HS-Messer/Blade = Art.-Nr./Item no. 36367
 Abweiser/Deflector = Art.-Nr./Item no. 3767

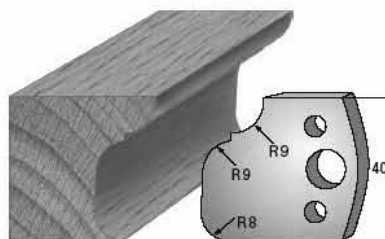

SP-Messer/Blade = Art.-Nr./Item no. 3668
 HS-Messer/Blade = Art.-Nr./Item no. 36368
 Abweiser/Deflector = Art.-Nr./Item no. 3768

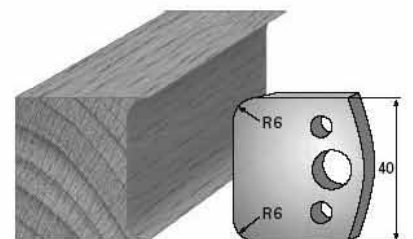

SP-Messer/Blade = Art.-Nr./Item no. 3669
 HS-Messer/Blade = Art.-Nr./Item no. 36369
 Abweiser/Deflector = Art.-Nr./Item no. 3769

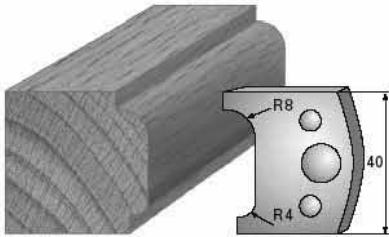

SP-Messer/Blade = Art.-Nr./Item no. 3670
HS-Messer/Blade = Art.-Nr./Item no. 36370
Abweiser/Deflector = Art.-Nr./Item no. 3770

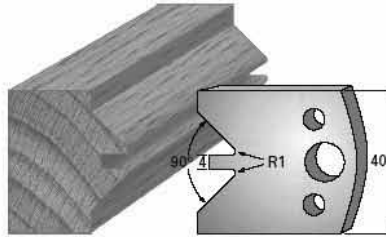

SP-Messer/Blade = Art.-Nr./Item no. 3671
HS-Messer/Blade = Art.-Nr./Item no. 36371
Abweiser/Deflector = Art.-Nr./Item no. 3771

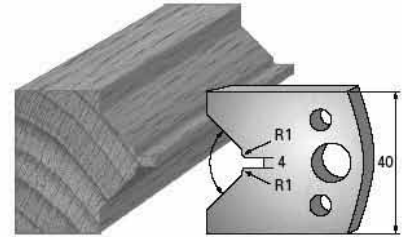

SP-Messer/Blade = Art.-Nr./Item no. 3672
HS-Messer/Blade = Art.-Nr./Item no. 36372
Abweiser/Deflector = Art.-Nr./Item no. 3772

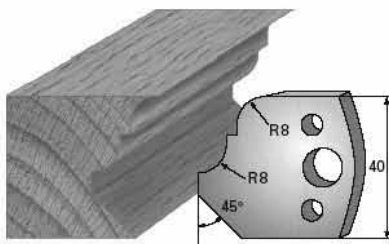

SP-Messer/Blade = Art.-Nr./Item no. 3673
HS-Messer/Blade = Art.-Nr./Item no. 36373
Abweiser/Deflector = Art.-Nr./Item no. 3773

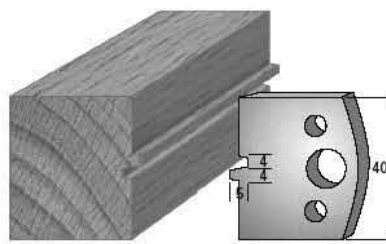

SP-Messer/Blade = Art.-Nr./Item no. 3674
HS-Messer/Blade = Art.-Nr./Item no. 36374
Abweiser/Deflector = Art.-Nr./Item no. 3774

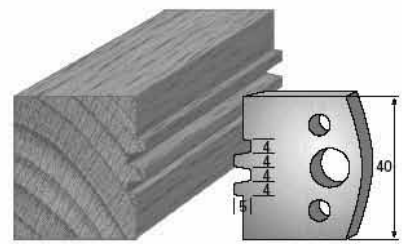

SP-Messer/Blade = Art.-Nr./Item no. 3675
HS-Messer/Blade = Art.-Nr./Item no. 36375
Abweiser/Deflector = Art.-Nr./Item no. 3775

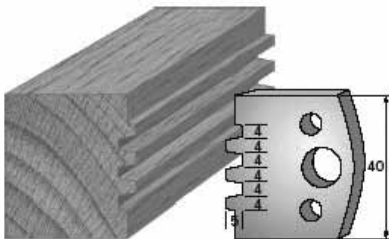

SP-Messer/Blade = Art.-Nr./Item no. 3676
HS-Messer/Blade = Art.-Nr./Item no. 36376
Abweiser/Deflector = Art.-Nr./Item no. 3776

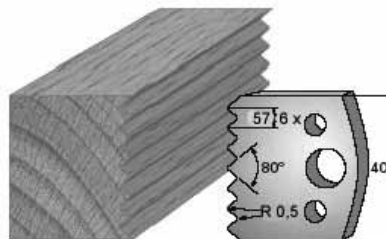

SP-Messer/Blade = Art.-Nr./Item no. 3677
HS-Messer/Blade = Art.-Nr./Item no. 36377
Abweiser/Deflector = Art.-Nr./Item no. 3777

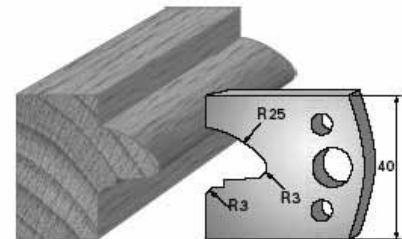

SP-Messer/Blade = Art.-Nr./Item no. 3678
HS-Messer/Blade = Art.-Nr./Item no. 36378
Abweiser/Deflector = Art.-Nr./Item no. 3778

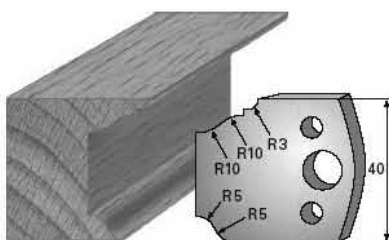

SP-Messer/Blade = Art.-Nr./Item no. 3679
HS-Messer/Blade = Art.-Nr./Item no. 36379
Abweiser/Deflector = Art.-Nr./Item no. 3779

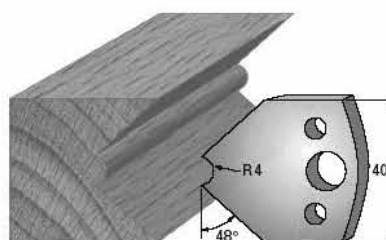

SP-Messer/Blade = Art.-Nr./Item no. 3680
HS-Messer/Blade = Art.-Nr./Item no. 36380
Abweiser/Deflector = Art.-Nr./Item no. 3780

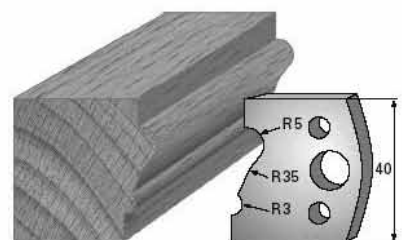

SP-Messer/Blade = Art.-Nr./Item no. 3681
HS-Messer/Blade = Art.-Nr./Item no. 36381
Abweiser/Deflector = Art.-Nr./Item no. 3781

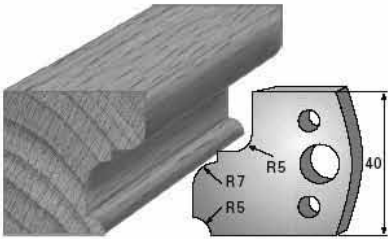

SP-Messer/Blade = Art.-Nr./Item no. 3682
 HS-Messer/Blade = Art.-Nr./Item no. 36382
 Abweiser/Deflector = Art.-Nr./Item no. 3782

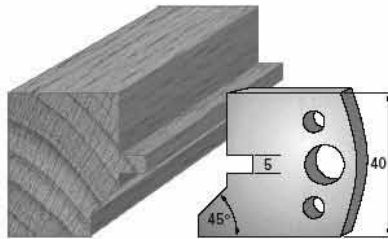

SP-Messer/Blade = Art.-Nr./Item no. 3683
 HS-Messer/Blade = Art.-Nr./Item no. 36383
 Abweiser/Deflector = Art.-Nr./Item no. 3783

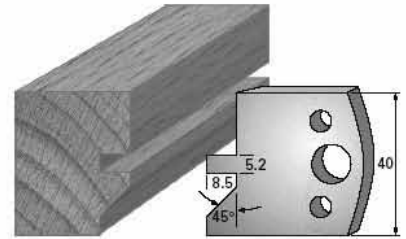

SP-Messer/Blade = Art.-Nr./Item no. 3684
 HS-Messer/Blade = Art.-Nr./Item no. 36384
 Abweiser/Deflector = Art.-Nr./Item no. 3784

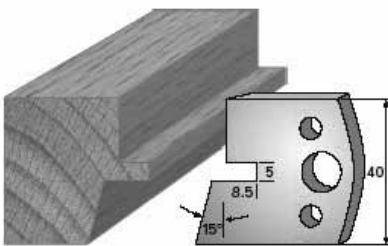

SP-Messer/Blade = Art.-Nr./Item no. 3685
 HS-Messer/Blade = Art.-Nr./Item no. 36385
 Abweiser/Deflector = Art.-Nr./Item no. 3785

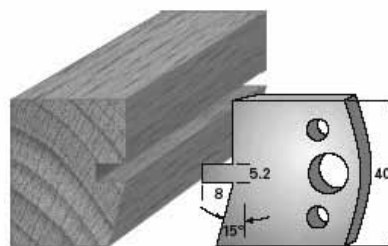

SP-Messer/Blade = Art.-Nr./Item no. 3686
 HS-Messer/Blade = Art.-Nr./Item no. 36386
 Abweiser/Deflector = Art.-Nr./Item no. 3786

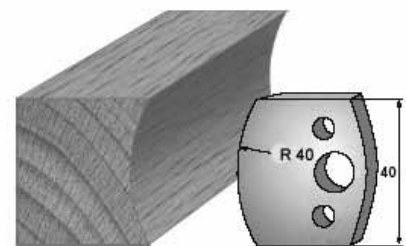

SP-Messer/Blade = Art.-Nr./Item no. 3687
 HS-Messer/Blade = Art.-Nr./Item no. 36387
 Abweiser/Deflector = Art.-Nr./Item no. 3787

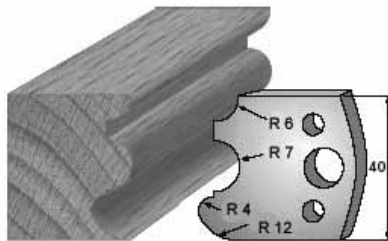

SP-Messer/Blade = Art.-Nr./Item no. 3688
 HS-Messer/Blade = Art.-Nr./Item no. 36388
 Abweiser/Deflector = Art.-Nr./Item no. 3788

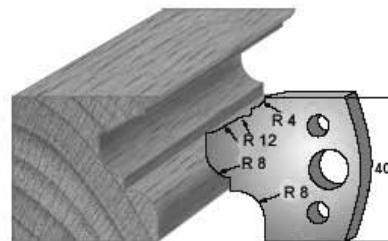

SP-Messer/Blade = Art.-Nr./Item no. 3689
 HS-Messer/Blade = Art.-Nr./Item no. 36389
 Abweiser/Deflector = Art.-Nr./Item no. 3789

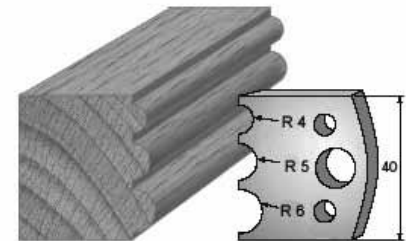

SP-Messer/Blade = Art.-Nr./Item no. 3690
 HS-Messer/Blade = Art.-Nr./Item no. 36390
 Abweiser/Deflector = Art.-Nr./Item no. 3790

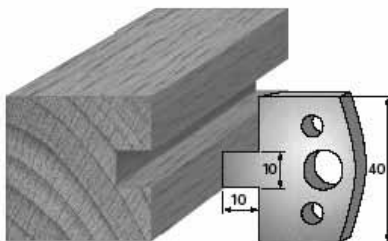

SP-Messer/Blade = Art.-Nr./Item no. 3691
 HS-Messer/Blade = Art.-Nr./Item no. 36391
 Abweiser/Deflector = Art.-Nr./Item no. 3791

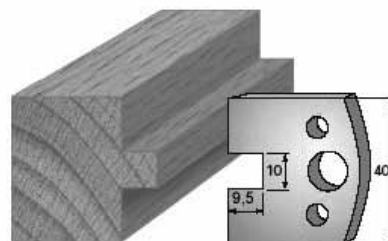

SP-Messer/Blade = Art.-Nr./Item no. 3692
 HS-Messer/Blade = Art.-Nr./Item no. 36392
 Abweiser/Deflector = Art.-Nr./Item no. 3792

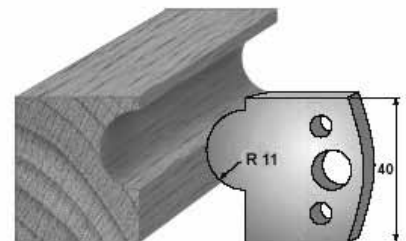

SP-Messer/Blade = Art.-Nr./Item no. 3693
 HS-Messer/Blade = Art.-Nr./Item no. 36393
 Abweiser/Deflector = Art.-Nr./Item no. 3793

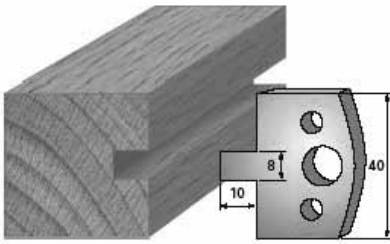

SP-Messer/Blade = Art.-Nr./Item no. 3694
HS-Messer/Blade = Art.-Nr./Item no. 36394
Abweiser/Deflector = Art.-Nr./Item no. 3794

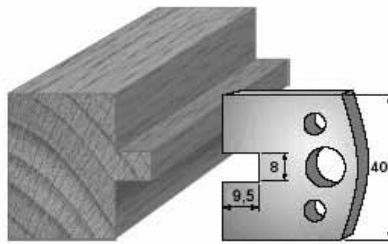

SP-Messer/Blade = Art.-Nr./Item no. 3695
HS-Messer/Blade = Art.-Nr./Item no. 36395
Abweiser/Deflector = Art.-Nr./Item no. 3795

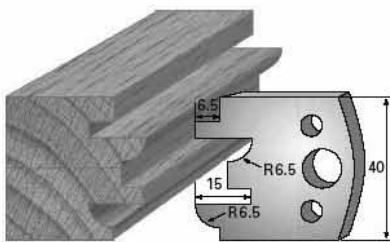
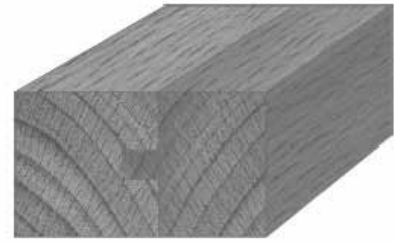

SP-Messer/Blade = Art.-Nr./Item no. 3696 - Konter 1
HS-Messer/Blade = Art.-Nr./Item no. 36396
Abweiser/Deflector = Art.-Nr./Item no. 3796

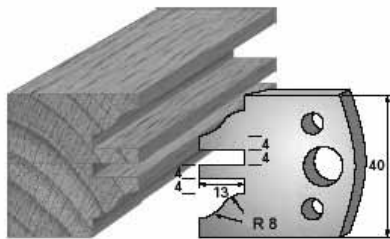

SP-Messer/Blade = Art.-Nr./Item no. 3697 - Konter 2
HS-Messer/Blade = Art.-Nr./Item no. 36397
Abweiser/Deflector = Art.-Nr./Item no. 3797

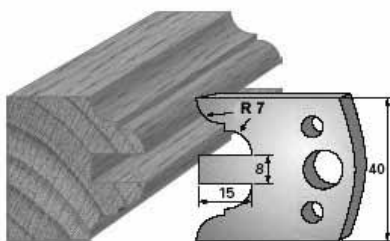

SP-Messer/Blade = Art.-Nr./Item no. 3698 - Konter 3
HS-Messer/Blade = Art.-Nr./Item no. 36398
Abweiser/Deflector = Art.-Nr./Item no. 3798

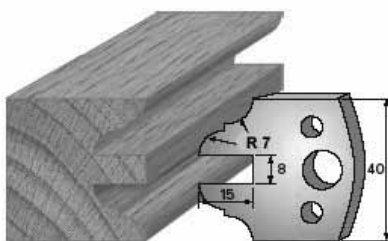

SP-Messer/Blade = Art.-Nr./Item no. 3699 - Konter 4
HS-Messer/Blade = Art.-Nr./Item no. 36399
Abweiser/Deflector = Art.-Nr./Item no. 3799



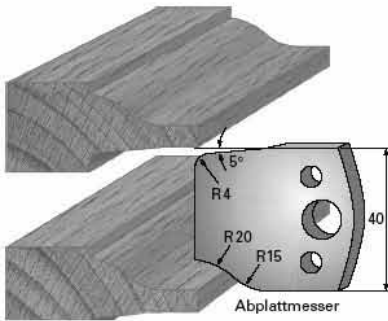

Abplattmesser

SP-Messer/Blade = Art.-Nr./Item no. 36100
 HS-Messer/Blade = Art.-Nr./Item no. 36400
 Abweiser/Deflector = Art.-Nr./Item no. 37100

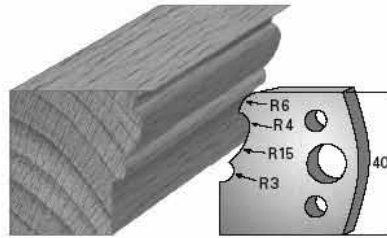

SP-Messer/Blade = Art.-Nr./Item no. 36101
 HS-Messer/Blade = Art.-Nr./Item no. 36401
 Abweiser/Deflector = Art.-Nr./Item no. 37101

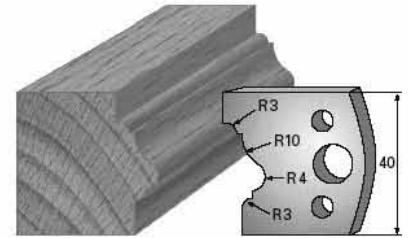

SP-Messer/Blade = Art.-Nr./Item no. 36102
 HS-Messer/Blade = Art.-Nr./Item no. 36402
 Abweiser/Deflector = Art.-Nr./Item no. 37102

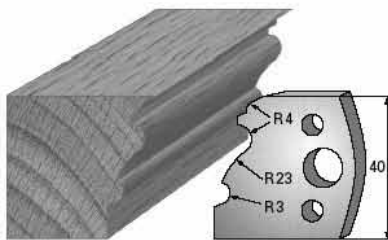

SP-Messer/Blade = Art.-Nr./Item no. 36103
 HS-Messer/Blade = Art.-Nr./Item no. 36403
 Abweiser/Deflector = Art.-Nr./Item no. 37103

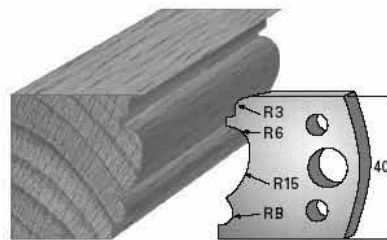

SP-Messer/Blade = Art.-Nr./Item no. 36104
 HS-Messer/Blade = Art.-Nr./Item no. 36404
 Abweiser/Deflector = Art.-Nr./Item no. 37104

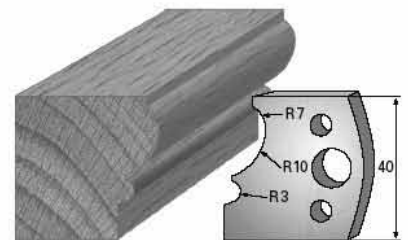

SP-Messer/Blade = Art.-Nr./Item no. 36105
 HS-Messer/Blade = Art.-Nr./Item no. 36405
 Abweiser/Deflector = Art.-Nr./Item no. 37105

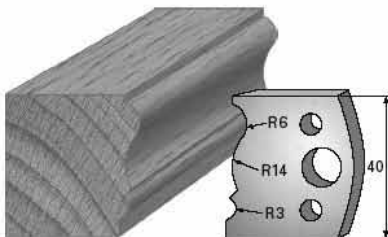

SP-Messer/Blade = Art.-Nr./Item no. 36106
 HS-Messer/Blade = Art.-Nr./Item no. 36406
 Abweiser/Deflector = Art.-Nr./Item no. 37106

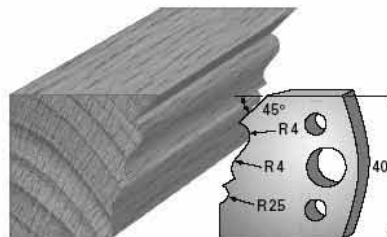

SP-Messer/Blade = Art.-Nr./Item no. 36107
 HS-Messer/Blade = Art.-Nr./Item no. 36407
 Abweiser/Deflector = Art.-Nr./Item no. 37107

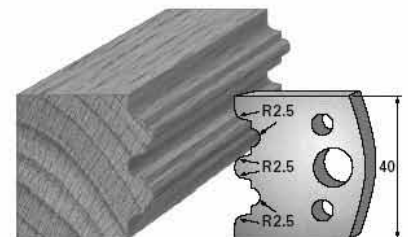

SP-Messer/Blade = Art.-Nr./Item no. 36108
 HS-Messer/Blade = Art.-Nr./Item no. 36408
 Abweiser/Deflector = Art.-Nr./Item no. 37108

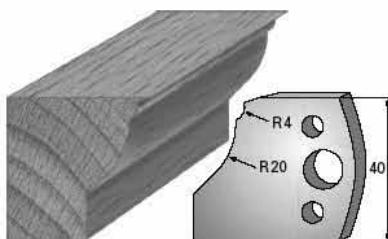

SP-Messer/Blade = Art.-Nr./Item no. 36109
 HS-Messer/Blade = Art.-Nr./Item no. 36409
 Abweiser/Deflector = Art.-Nr./Item no. 37109

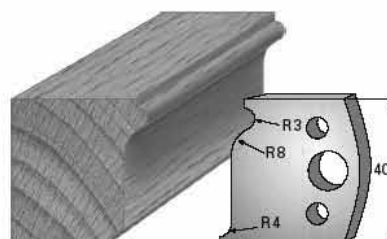

SP-Messer/Blade = Art.-Nr./Item no. 36110
 HS-Messer/Blade = Art.-Nr./Item no. 36410
 Abweiser/Deflector = Art.-Nr./Item no. 37110

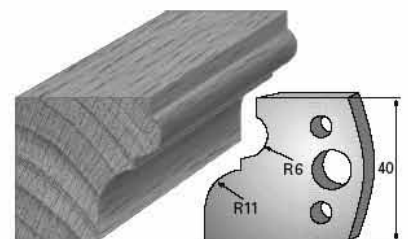

SP-Messer/Blade = Art.-Nr./Item no. 36111
 HS-Messer/Blade = Art.-Nr./Item no. 36411
 Abweiser/Deflector = Art.-Nr./Item no. 37111

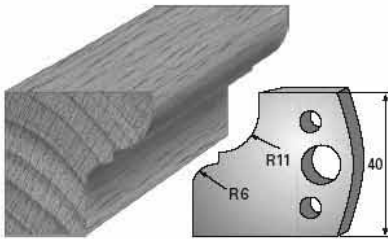

SP-Messer/Blade = Art.-Nr./Item no. 36112
HS-Messer/Blade = Art.-Nr./Item no. 36412
Abweiser/Deflector = Art.-Nr./Item no. 37112

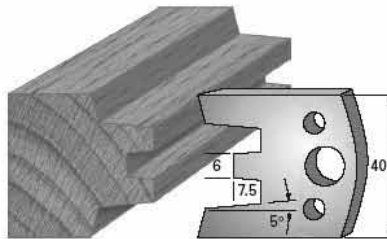

SP-Messer/Blade = Art.-Nr./Item no. 36113
HS-Messer/Blade = Art.-Nr./Item no. 36413
Abweiser/Deflector = Art.-Nr./Item no. 37113

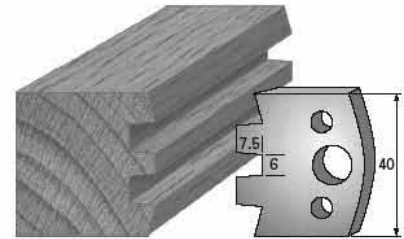

SP-Messer/Blade = Art.-Nr./Item no. 36114
HS-Messer/Blade = Art.-Nr./Item no. 36414
Abweiser/Deflector = Art.-Nr./Item no. 37114

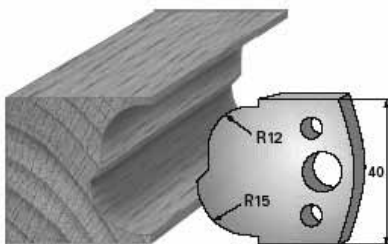

SP-Messer/Blade = Art.-Nr./Item no. 36115
HS-Messer/Blade = Art.-Nr./Item no. 36415
Abweiser/Deflector = Art.-Nr./Item no. 37115

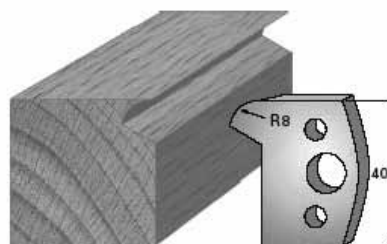

SP-Messer/Blade = Art.-Nr./Item no. 36116
HS-Messer/Blade = Art.-Nr./Item no. 36416
Abweiser/Deflector = Art.-Nr./Item no. 37116

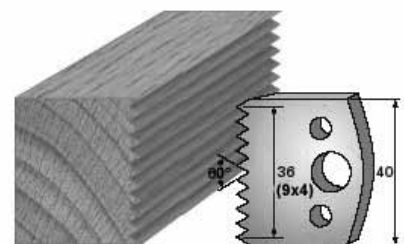

SP-Messer/Blade = Art.-Nr./Item no. 36117
HS-Messer/Blade = Art.-Nr./Item no. 36417
Abweiser/Deflector = Art.-Nr./Item no. 37117

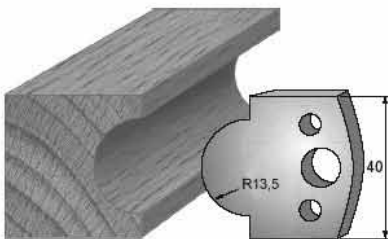

SP-Messer/Blade = Art.-Nr./Item no. 36118
HS-Messer/Blade = Art.-Nr./Item no. 36418
Abweiser/Deflector = Art.-Nr./Item no. 37118

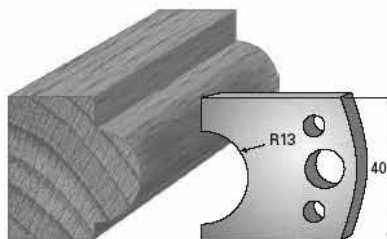

SP-Messer/Blade = Art.-Nr./Item no. 36119
HS-Messer/Blade = Art.-Nr./Item no. 36419
Abweiser/Deflector = Art.-Nr./Item no. 37119

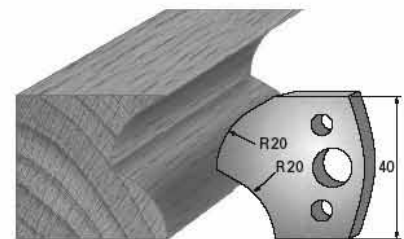

SP-Messer/Blade = Art.-Nr./Item no. 36120
HS-Messer/Blade = Art.-Nr./Item no. 36420
Abweiser/Deflector = Art.-Nr./Item no. 37120

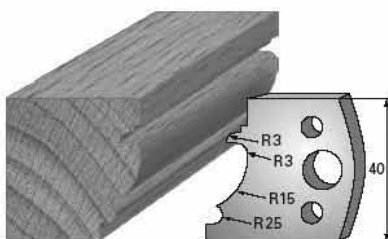

SP-Messer/Blade = Art.-Nr./Item no. 36121
HS-Messer/Blade = Art.-Nr./Item no. 36421
Abweiser/Deflector = Art.-Nr./Item no. 37121

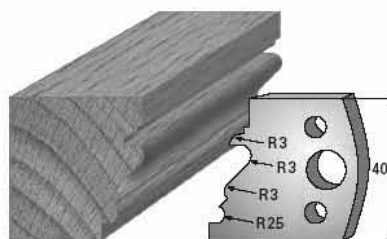

SP-Messer/Blade = Art.-Nr./Item no. 36122
HS-Messer/Blade = Art.-Nr./Item no. 36422
Abweiser/Deflector = Art.-Nr./Item no. 37122

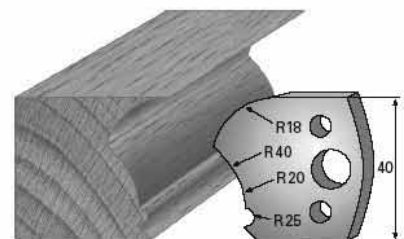

SP-Messer/Blade = Art.-Nr./Item no. 36123
HS-Messer/Blade = Art.-Nr./Item no. 36423
Abweiser/Deflector = Art.-Nr./Item no. 37123

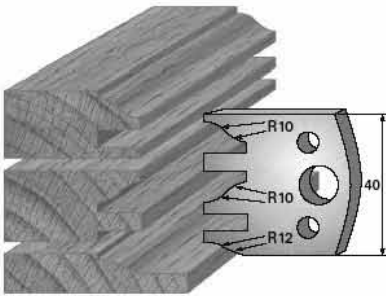

SP-Messer/Blade = Art.-Nr./Item no. 36124
 HS-Messer/Blade = Art.-Nr./Item no. 36424
 Abweiser/Deflector = Art.-Nr./Item no. 37124

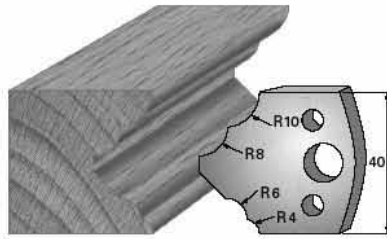

SP-Messer/Blade = Art.-Nr./Item no. 36125
 HS-Messer/Blade = Art.-Nr./Item no. 36425
 Abweiser/Deflector = Art.-Nr./Item no. 37125

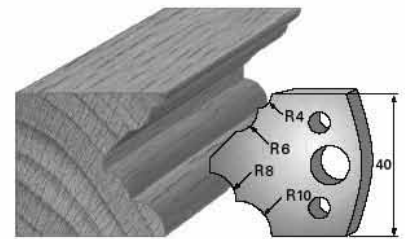

SP-Messer/Blade = Art.-Nr./Item no. 36126
 HS-Messer/Blade = Art.-Nr./Item no. 36426
 Abweiser/Deflector = Art.-Nr./Item no. 37126

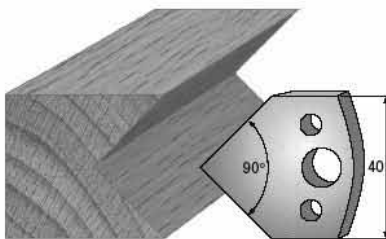

SP-Messer/Blade = Art.-Nr./Item no. 36127
 HS-Messer/Blade = Art.-Nr./Item no. 36427
 Abweiser/Deflector = Art.-Nr./Item no. 37127

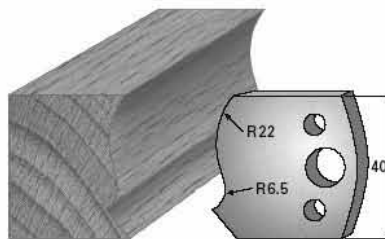

SP-Messer/Blade = Art.-Nr./Item no. 36128
 HS-Messer/Blade = Art.-Nr./Item no. 36428
 Abweiser/Deflector = Art.-Nr./Item no. 37128

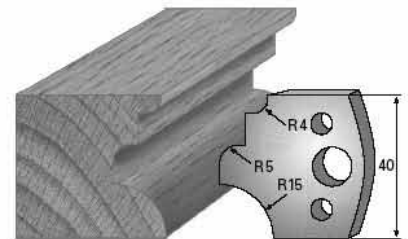

SP-Messer/Blade = Art.-Nr./Item no. 36129
 HS-Messer/Blade = Art.-Nr./Item no. 36429
 Abweiser/Deflector = Art.-Nr./Item no. 37129

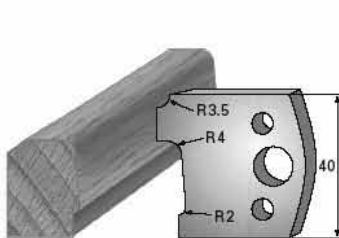

SP-Messer/Blade = Art.-Nr./Item no. 36130
 HS-Messer/Blade = Art.-Nr./Item no. 36430
 Abweiser/Deflector = Art.-Nr./Item no. 37130

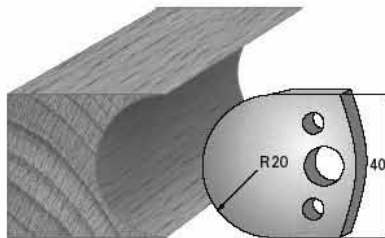

SP-Messer/Blade = Art.-Nr./Item no. 36131
 HS-Messer/Blade = Art.-Nr./Item no. 36431
 Abweiser/Deflector = Art.-Nr./Item no. 37131

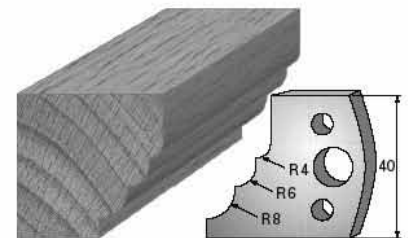

SP-Messer/Blade = Art.-Nr./Item no. 36132
 HS-Messer/Blade = Art.-Nr./Item no. 36432
 Abweiser/Deflector = Art.-Nr./Item no. 37132

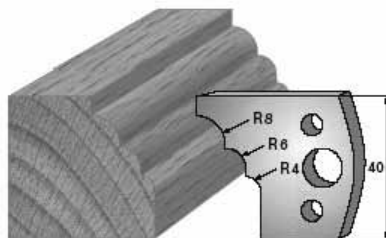

SP-Messer/Blade = Art.-Nr./Item no. 36133
 HS-Messer/Blade = Art.-Nr./Item no. 36433
 Abweiser/Deflector = Art.-Nr./Item no. 37133

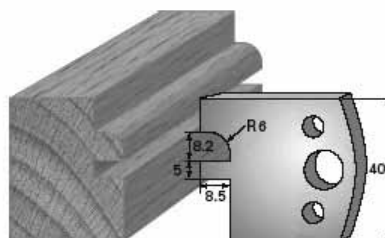

SP-Messer/Blade = Art.-Nr./Item no. 36134
 HS-Messer/Blade = Art.-Nr./Item no. 36434
 Abweiser/Deflector = Art.-Nr./Item no. 37134

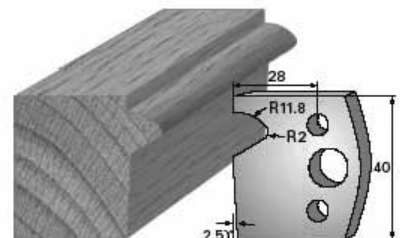

SP-Messer/Blade = Art.-Nr./Item no. 36135
 HS-Messer/Blade = Art.-Nr./Item no. 36435
 Abweiser/Deflector = Art.-Nr./Item no. 37135

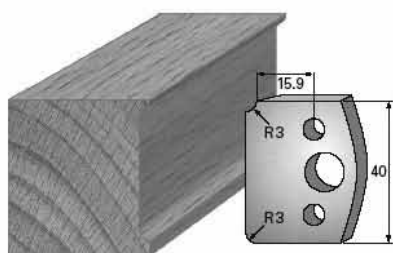

SP-Messer/Blade = Art.-Nr./Item no. 36170
HS-Messer/Blade = Art.-Nr./Item no. 36470
Abweiser/Deflector = Art.-Nr./Item no. 37170

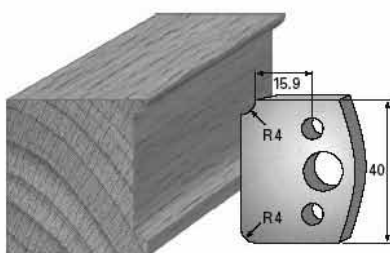

SP-Messer/Blade = Art.-Nr./Item no. 36171
HS-Messer/Blade = Art.-Nr./Item no. 36471
Abweiser/Deflector = Art.-Nr./Item no. 37171

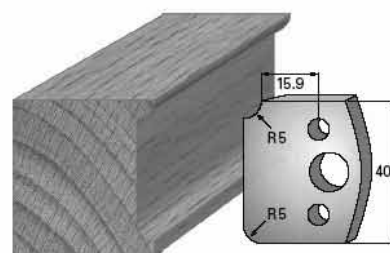

SP-Messer/Blade = Art.-Nr./Item no. 36172
HS-Messer/Blade = Art.-Nr./Item no. 36472
Abweiser/Deflector = Art.-Nr./Item no. 37172

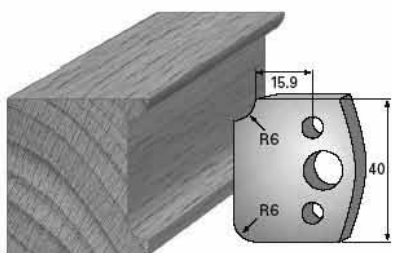

SP-Messer/Blade = Art.-Nr./Item no. 36173
HS-Messer/Blade = Art.-Nr./Item no. 36473
Abweiser/Deflector = Art.-Nr./Item no. 37173

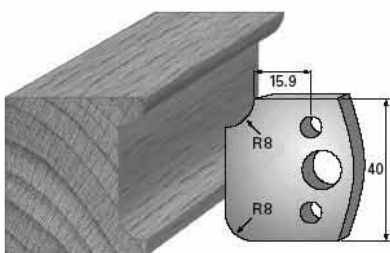

SP-Messer/Blade = Art.-Nr./Item no. 36174
HS-Messer/Blade = Art.-Nr./Item no. 36474
Abweiser/Deflector = Art.-Nr./Item no. 37174

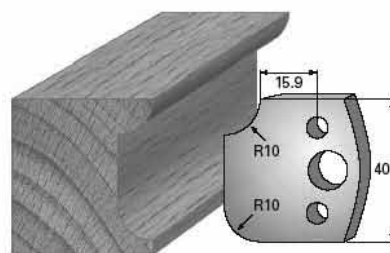

SP-Messer/Blade = Art.-Nr./Item no. 36175
HS-Messer/Blade = Art.-Nr./Item no. 36475
Abweiser/Deflector = Art.-Nr./Item no. 37175

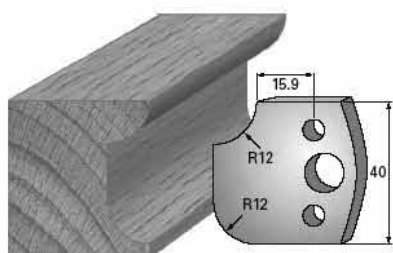

SP-Messer/Blade = Art.-Nr./Item no. 36176
HS-Messer/Blade = Art.-Nr./Item no. 36476
Abweiser/Deflector = Art.-Nr./Item no. 37176

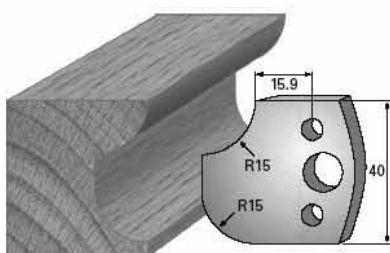

SP-Messer/Blade = Art.-Nr./Item no. 36177
HS-Messer/Blade = Art.-Nr./Item no. 36477
Abweiser/Deflector = Art.-Nr./Item no. 37177

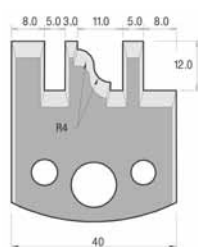

SP-Messer/Blade = Art.-Nr./Item no. 36136
HS-Messer/Blade = Art.-Nr./Item no. 36436
Abweiser/Deflector = Art.-Nr./Item no. 37136

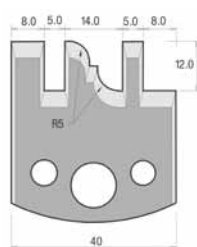

SP-Messer/Blade = Art.-Nr./Item no. 36137
HS-Messer/Blade = Art.-Nr./Item no. 36437
Abweiser/Deflector = Art.-Nr./Item no. 37137

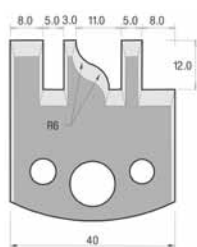

SP-Messer/Blade = Art.-Nr./Item no. 36138
HS-Messer/Blade = Art.-Nr./Item no. 36438
Abweiser/Deflector = Art.-Nr./Item no. 37138

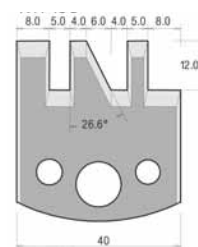

SP-Messer/Blade = Art.-Nr./Item no. 36139
HS-Messer/Blade = Art.-Nr./Item no. 36439
Abweiser/Deflector = Art.-Nr./Item no. 37139

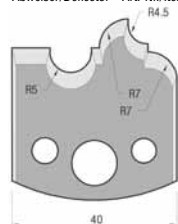

SP-Messer/Blade = Art.-Nr./Item no. 36140
HS-Messer/Blade = Art.-Nr./Item no. 36440
Abweiser/Deflector = Art.-Nr./Item no. 37140

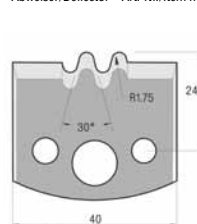

SP-Messer/Blade = Art.-Nr./Item no. 36141
HS-Messer/Blade = Art.-Nr./Item no. 36441
Abweiser/Deflector = Art.-Nr./Item no. 37141

**Neue Profile Nr. 136 - 141
in 40 mm Breite**
**New profiles no. 136 - 141
in 40 mm width**

UNIVERSAL- Profilmesserkopf Z 2

für Profilmesser 40/50 x 4 mm - EURO-System

UNIVERSAL- head Z 2

for profiling blades 40/50 x 4 mm - EURO-system



Ausführung:

Werkzeugkörper aus Stahl, spandickenbegrenzt, rückschlagarm, vorzugsweise für Handvorschubarbeiten.

Formschlüssige Messer- und Abweiserbefestigung auf konstanten Flugkreis.

Profilmesser aus **SP-Stahl** und **HS-Stahl**, seitlich hinterschliften lieferbar!

Grundwerkzeug wird mit 40 mm Falzmesser in SP-Stahl bestückt geliefert!

Max. Profiltiefe 17 mm.

Profilmesser 40 + 50 mm einsetzbar.

Design:

Universal head for profiling blades, chip-thickness limitation, reduced recoil, preferably for manual feed. Tool made from steel. Positive blade and deflector fastening with constant cutting circle.

Profiling blades with lateral set-off. Blades made from special steel and high-speed steel.

Basic tool incl. rabbeting blade in special steel.

Max. profile depth 17 mm.

Profile blades 40 + 50 mm can be used.



Art.-Nr./Item no. 3910

Anwendung:

Vorwiegend zum Profilieren von Weich- und Harthölzern (Vollholz unverleimt).

Profilmesser mit den jeweils passenden Abweisern sind stets paarweise einzusetzen.

Application:

Preferably for soft- and hardwood (unglued solid wood).

Profiling blades and the corresponding deflectors to be used in pairs.

Artikel-Nr. Item no.	Abmessung mm Dimensions mm D/D B/W d/b	Z	Ausführung Quality	n/min ⁻¹	EURO Stück/pce
3910	114 x 40/50 x 30	2	Stahl/Steel	5.100 - 7.900	
3911	114 x 40/50 x 40	2	Stahl/Steel	5.100 - 7.900	

UNIVERSAL-Werkzeug-Sätze,
best. aus Kopf 114 x 40/50 x 30 mm Stahl (Art.-Nr. 3910) und entsprechender Anzahl Profilmesser und Abweiser (paarweise) in SP-Stahl in Holzkassette.

UNIVERSAL tool sets,

consists of head 114 x 40/50 x 30 mm steel (No. 3910) and the relevant number of profile knives and deflector (in pairs) in SP-steel in wooden box.

Artikel-Nr. Item no.	Bezeichnung Description	Profil-Nr. Profile	EURO Stück/pce
3906	UNI-Set mit 6 Profilen in Holzkassette / set with 6 profiles	501 - 506	
3913	UNI-Set mit 12 Profilen in Holzkassette / set with 12 profiles	501 - 512	
3916	UNI-Set mit 24 Profilen in Holzkassette / set with 24 profiles	501 - 520 524, 541 - 543	
3906HK	Holzkassette für 6 Profilsätze, leer / empty box for 6 profile sets		
3913HK	Holzkassette für 12 Profilsätze, leer / empty box for 12 profile sets		
3916HK	Holzkassette für 24 Profilsätze, leer / empty box for 24 profile sets		

Profilmesser und Abweiser (Abgabe ausschließlich paarweise)

Profiling blades and deflectors (only in pairs)

Artikel-Nr. Item no.	Bezeichnung Description	Profil-Nr. Profile	EURO Stück/pce
38500 - 38519	UNI-Profilmesser 50 x 4 mm SP-Stahl/UNI Profiling blade 50 x 4 mm special steel	500 - 519	
38520 - 38524	UNI-Profilmesser 50 x 4 mm SP-Stahl/UNI Profiling blade 50 x 4 mm special steel	520 - 524	
38541 - 38580	UNI-Profilmesser 50 x 4 mm SP-Stahl/UNI Profiling blade 50 x 4 mm special steel	541 - 580	
36500 - 36580	UNI-Profilmesser 50 x 4 mm HS-Stahl/UNI Profiling blade 50 x 4 mm HS	500 - 580	
39500 - 39580	Abweiser 48 mm/Deflector 48 mm	500 - 580	
36903	Blankett 50 x 4 mm - HS/Blank 50 x 4 mm - HS		
37306	Blankett 48 x 4 mm - Abweiser/Deflector 48 x 4 mm		

MULTI-PROFIL **System** **50 mm („EURO-System“-kompatibel)**
50 mm (compatible with EURO-system)



Ausführung:

Das **MULTI-PROFIL**-Messer-System besteht aus jeweils profilierter Trägerplatte + profilierter Schneidplatte (HW-Qualität) + profilierter Abweiserplatte.

Achtung: lt. BG-Vorschrift erfolgt Abgabe stets satzweise bzw. paarweise!!

Das System ist im eingebauten Zustand form- und kraftschlüssig, rückschlagarm, in Verbindung mit Abweiserplatten für Handvorschubarbeiten, ansonsten jedoch auch für mech. Vorschub und CNC-Einsatz geeignet.

Alle Schneidplatten sind grundsätzlich seitlich hinterschlifften!

Das Messer-System passt ohne Änderungen in alle handelsübliche UNI-Profil-Messerköpfe „Euro-System“!

Anwendung:

Vorwiegend zum Profilieren von Abrasivstoffen wie Corian, MDF, Multiplex und anderen Verbundstoffen/Leimhölzern geeignet.

Abbildungen der lieferbaren Profile siehe BRÜCK-Katalog Produktgruppe 6; Seiten 6.21 - 6.26

Design:

The **MULTI-PROFILING** system consists of a profiled blade holder + profiled blade (TC) each.

Attention: Blades and deflectors have to be used in pairs !!

This system has a form- and force-locked tension, reduced recoil, in combination with deflectors preferably for manual feed. Otherwise also usable for mec. feed and operation on CNC machines.

All blades have a laterally relief-ground.

This system is usable for all customary UNIVERSAL cutter heads, „EURO-system“, without any changes.

Application:

Mainly used for profiling abrasive materials like Corian, MDF, Multiplex, other boards or glued woods.

Pictures of all available profiles are shown in our catalogue product group 6, page 6.21 - 6.26

DAS SYSTEM:

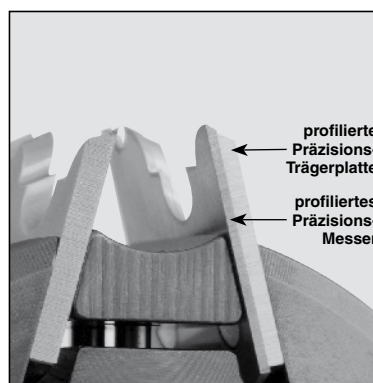
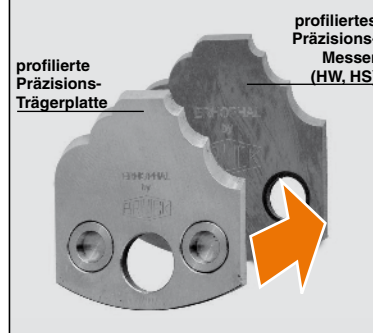

Standardprofile/Standard Profiles

Artikel-Nr. Item no.	Bezeichnung Description	Profil-Nr. profile no.	EURO Stück/pce
38500HW - 38580HW	Profil-Messer HW-Qualität/profiling blade TC-quality	0 - 80	
37500TP - 37580TP	Profil-Trägerplatten/profile blade holder	0 - 80	
39500 - 39580	Profil-Abweiser/profile deflector	0 - 80	
38500HWS - 38580HWS	Kompl. HW-Profilmessersatz best. aus: 2 Messern, 2 Trägerplatten und 2 Abweisern Complete TC-profile blade set consists of: 2 blades, 2 blade holders and 2 deflectors	0 - 80	

Blanketts/Blanks

35903HWS	HW-Messersatz-Blanketts/TC-blade set blanks (je 2x Messer & Trägerplatten)/(2x blades & blade holder each)	
----------	--	--

Sonderprofile/Special Profiles

Profilgruppe profile category	Artikel-Nr./Item no. HW-Qualität/TC-quality	EURO Stück/pce HW/TC
----------------------------------	--	----------------------------

A) kompl. Satz bestehend aus: jeweils 2 Messern, 2 Trägerplatten und 2 Abweisern
A) complete set consists of: 2 blades, 2 blade holders and 2 deflectors each

1	38501HWS-SO	
2	38502HWS-SO	
3	38503HWS-SO	

B) Nachbestellung pro Paar Ersatzmesser
B) repeat order/price for one pair replacement blades

1	38501HW-SO	
2	38502HW-SO	
3	38503HW-SO	

UNI-Profil- und Falzmesserkopf Z 2

mit Vorschneider u. HW-WP-Bestückung 40 x 12 x 1,5 mm



Universal profiling- and rebating head Z 2

with TC-roughing tooth and TC-interchangeable blades 40 x 12 x 1,5 mm

Ausführung:

3590 (f. 40 mm UNI-Profilmesser),
 Werkzeugkörper aus hochfestem
 Leichtmetall mit Eloxalbeschichtung.
3912 (f. 40/50 mm UNI-Profilmesser),
 Werkzeugkörper aus Stahl.
 Spandickenbegrenzt, rückschlagarm,
 vorzugsweise für Handvorschubarbeiten.
 Bestückt mit Messerhalter f. HW-WP,
 HW-WP 40 x 12 x 1,5 mm, Abweiser und
 HW-Vorschneider 14 x 14 x 2,0 mm
Ansonsten sind alle UNI-Profilmesser
40 x 4 mm und 50 x 4 mm
(EURO-System) einsetzbar!
 (s.Katalog PG 6 - Seiten 6.5 - 6.17)

Design:

3590 (for 40 mm UNI-profiling blades).
*Tool made from light metal with high
 tensile strength, anodised coated.*
3912 (for 40/50 mm UNI-profiling blades).
Body made from steel.
*Chip thickness limitation, reduced recoil,
 preferably for manual feed.*
*Fit with blade holder for TC-interchange-
 able blades 40 x 12 x 1,5 mm, deflector
 and TC-roughing tooth 14 x 14 x 2,0 mm*
Otherwise all UNI-profiling blades
40 x 4 mm and 50 x 4 mm
(EURO-system) are usable!
 (see catalogue PG 6 - page 6.5 - 6.17)



Art.-Nr./Item no. 3912

Anwendung:

Zum Falzen von Plattenwerkstoffen wie
 Sperrholz und Tischler-, Span- und Hart-
 faserplatten mit und ohne Kunststoff-
 beschichtung oder Furnier, verleimten
 Hölzern sowie zum Profilieren von
 Massivhölzern. Die Profilmesser 40 x 4
 bzw. 50 x 4 mm und Abweiser sind stets
 profilgleich paarweise einzusetzen.

Application:

*For rebating boards with or without
 veneer or plastic coating, modified and
 high-density wood, glued solid wood and
 also for profiling solid woods. The pro-
 filing blades 40 x 4 mm and 50 x 4 mm
 and deflectors have to be used in pairs.*

Artikel-Nr. Item no.	Bezeichnung Description	Abmessungen in mm Dimensions in mm	Schneiden Cutting	n/min ⁻¹	EURO Stück/pce
3590	UNI-Profil- und Falzmesserkopf kpl. m. HW-Vorschneider u. HW-WP UNI-profiling- and rebating cutter head with TC-roughing tooth and TC-interchangeable blades	98 x 40 x 30	Z2/V2	5.800 - 9.000	
3912	UNI-Profil- und Falzmesserkopf kpl. m. HW-Vorschneider u. HW-WP UNI-profiling- and rebating cutter head with TC-roughing tooth and TC-interchangeable blades	117 x 40/50 x 30	Z2/V2	5.000 - 7.900	

Ersatz-Wendepplatten Replacement parts

Weitere Ersatzteile (Schrauben, Spannkeile usw.) siehe Seite 14.5 - 14.9
 More Replacement parts (screws, wedges etc.) see page 14.5 - 14.9

Artikel-Nr. Item no.	Bezeichnung Description	EURO Stück/pce
01040012	HW-Wendepplatte 40 x 12 x 1,5 mm TC-interchangeable blade 40 x 12 x 1,5 mm	
01014142	HW-Vorschneider 14 x 14 x 2,0 mm TC-roughing tooth 14 x 14 x 2,0 mm	

Sonderleistung wie z.B. andere Bohrungen - auf Anfrage.
 Andere Abmessungen und Ausführungen - auf Anfrage.

Verpackungseinheit für Ersatzplatten: 10 Stück

Extras such as different bores upon request.
 Other dimensions and designs upon request.

Packing quantities for replacement bands: 10 pcs

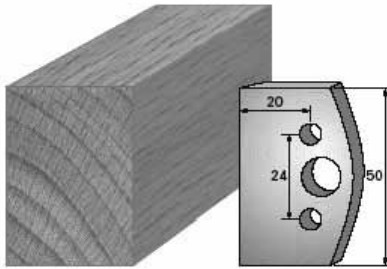

SP-Messer/Blade = Art.-Nr./Item no. 38500
HS-Messer/Blade = Art.-Nr./Item no. 36500
Abweiser/Deflector = Art.-Nr./Item no. 39500

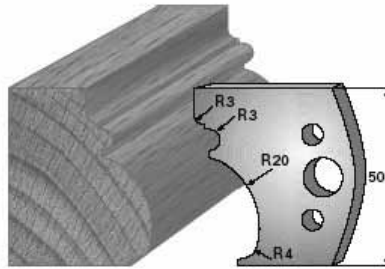

SP-Messer/Blade = Art.-Nr./Item no. 38501
HS-Messer/Blade = Art.-Nr./Item no. 36501
Abweiser/Deflector = Art.-Nr./Item no. 39501

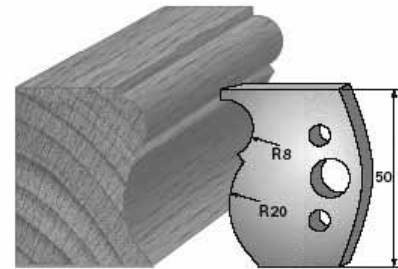

SP-Messer/Blade = Art.-Nr./Item no. 38502
HS-Messer/Blade = Art.-Nr./Item no. 36502
Abweiser/Deflector = Art.-Nr./Item no. 39502

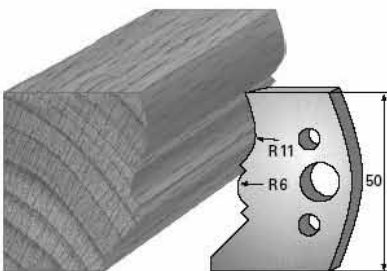

SP-Messer/Blade = Art.-Nr./Item no. 38503
HS-Messer/Blade = Art.-Nr./Item no. 36503
Abweiser/Deflector = Art.-Nr./Item no. 39503

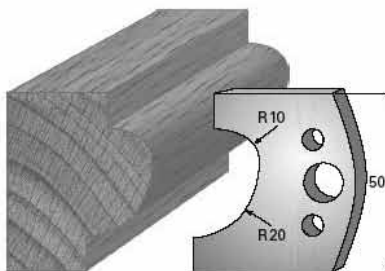

SP-Messer/Blade = Art.-Nr./Item no. 38504
HS-Messer/Blade = Art.-Nr./Item no. 36504
Abweiser/Deflector = Art.-Nr./Item no. 39504

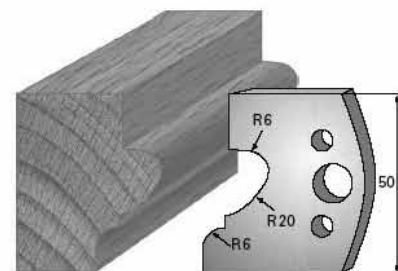

SP-Messer/Blade = Art.-Nr./Item no. 38505
HS-Messer/Blade = Art.-Nr./Item no. 36505
Abweiser/Deflector = Art.-Nr./Item no. 39505

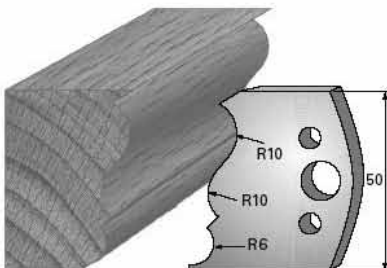

SP-Messer/Blade = Art.-Nr./Item no. 38506
HS-Messer/Blade = Art.-Nr./Item no. 36506
Abweiser/Deflector = Art.-Nr./Item no. 39506

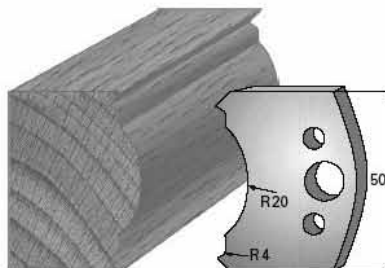

SP-Messer/Blade = Art.-Nr./Item no. 38507
HS-Messer/Blade = Art.-Nr./Item no. 36507
Abweiser/Deflector = Art.-Nr./Item no. 39507

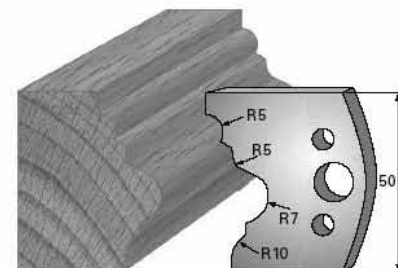

SP-Messer/Blade = Art.-Nr./Item no. 38508
HS-Messer/Blade = Art.-Nr./Item no. 36508
Abweiser/Deflector = Art.-Nr./Item no. 39508

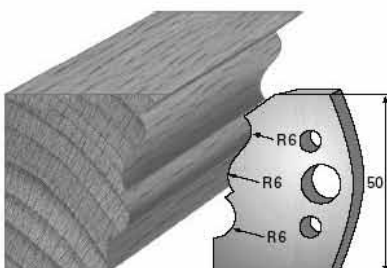

SP-Messer/Blade = Art.-Nr./Item no. 38509
HS-Messer/Blade = Art.-Nr./Item no. 36509
Abweiser/Deflector = Art.-Nr./Item no. 39509

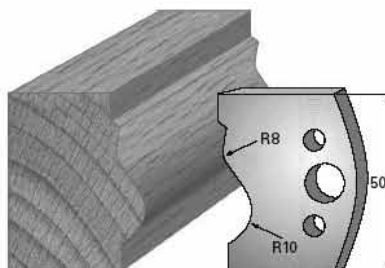

SP-Messer/Blade = Art.-Nr./Item no. 38510
HS-Messer/Blade = Art.-Nr./Item no. 36510
Abweiser/Deflector = Art.-Nr./Item no. 39510

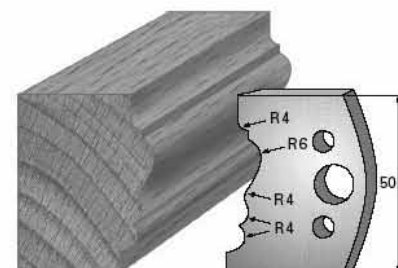

SP-Messer/Blade = Art.-Nr./Item no. 38511
HS-Messer/Blade = Art.-Nr./Item no. 36511
Abweiser/Deflector = Art.-Nr./Item no. 39511

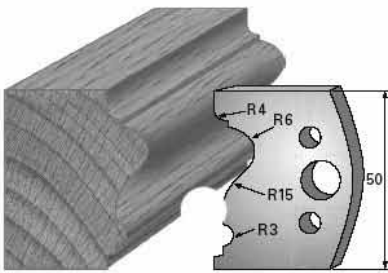

SP-Messer/Blade = Art.-Nr./Item no. 38512
 HS-Messer/Blade = Art.-Nr./Item no. 36512
 Abweiser/Deflector = Art.-Nr./Item no. 39512

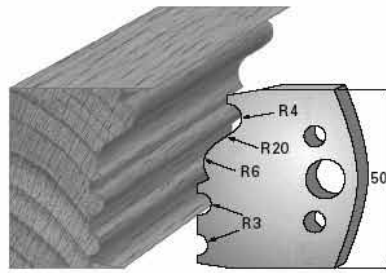

SP-Messer/Blade = Art.-Nr./Item no. 38513
 HS-Messer/Blade = Art.-Nr./Item no. 36513
 Abweiser/Deflector = Art.-Nr./Item no. 39513

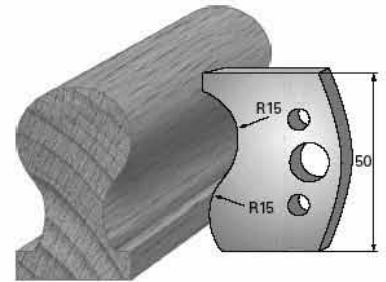

SP-Messer/Blade = Art.-Nr./Item no. 38514
 HS-Messer/Blade = Art.-Nr./Item no. 36514
 Abweiser/Deflector = Art.-Nr./Item no. 39514

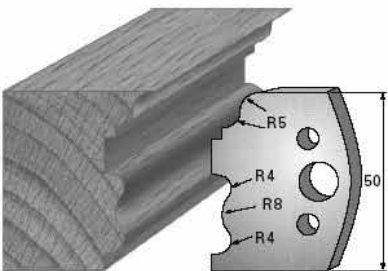

SP-Messer/Blade = Art.-Nr./Item no. 38515
 HS-Messer/Blade = Art.-Nr./Item no. 36515
 Abweiser/Deflector = Art.-Nr./Item no. 39515

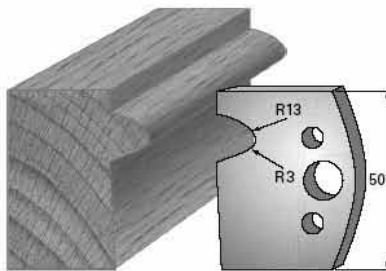

SP-Messer/Blade = Art.-Nr./Item no. 38516
 HS-Messer/Blade = Art.-Nr./Item no. 36516
 Abweiser/Deflector = Art.-Nr./Item no. 39516

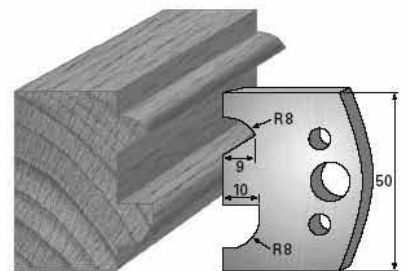

SP-Messer/Blade = Art.-Nr./Item no. 38517
 HS-Messer/Blade = Art.-Nr./Item no. 36517
 Abweiser/Deflector = Art.-Nr./Item no. 39517

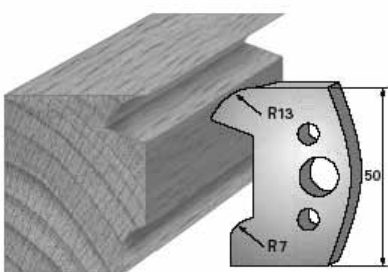

SP-Messer/Blade = Art.-Nr./Item no. 38518
 HS-Messer/Blade = Art.-Nr./Item no. 36518
 Abweiser/Deflector = Art.-Nr./Item no. 39518

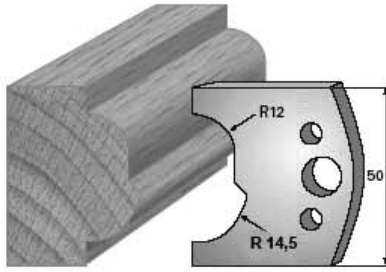

SP-Messer/Blade = Art.-Nr./Item no. 38519
 HS-Messer/Blade = Art.-Nr./Item no. 36519
 Abweiser/Deflector = Art.-Nr./Item no. 39519

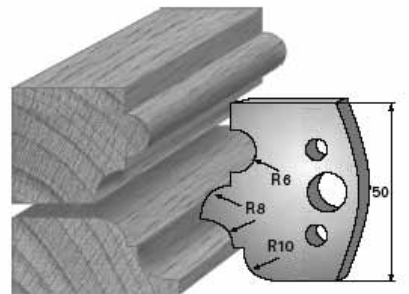

SP-Messer/Blade = Art.-Nr./Item no. 38520
 HS-Messer/Blade = Art.-Nr./Item no. 36520
 Abweiser/Deflector = Art.-Nr./Item no. 39520

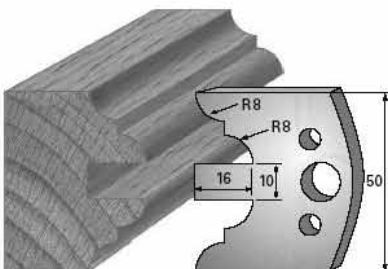

SP-Messer/Blade = Art.-Nr./Item no. 38522
 HS-Messer/Blade = Art.-Nr./Item no. 36522
 Abweiser/Deflector = Art.-Nr./Item no. 39522

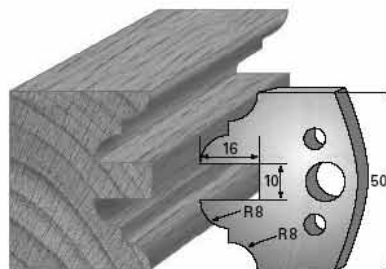

SP-Messer/Blade = Art.-Nr./Item no. 38523
 HS-Messer/Blade = Art.-Nr./Item no. 36523
 Abweiser/Deflector = Art.-Nr./Item no. 39523

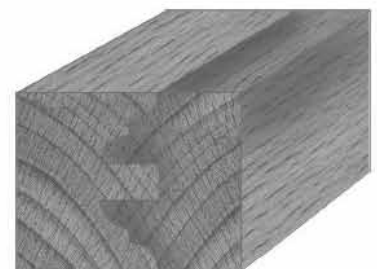

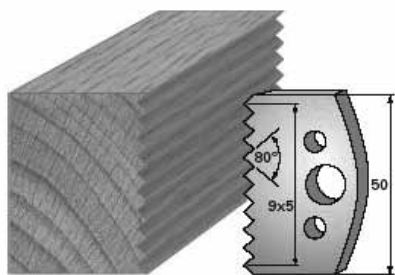

SP-Messer/Blade = Art.-Nr./Item no. 38524
HS-Messer/Blade = Art.-Nr./Item no. 36524
Abweiser/Deflector = Art.-Nr./Item no. 39524

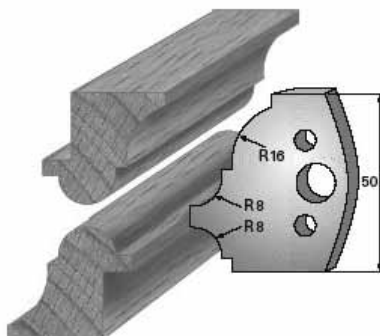

SP-Messer/Blade = Art.-Nr./Item no. 38541
HS-Messer/Blade = Art.-Nr./Item no. 36541
Abweiser/Deflector = Art.-Nr./Item no. 39541

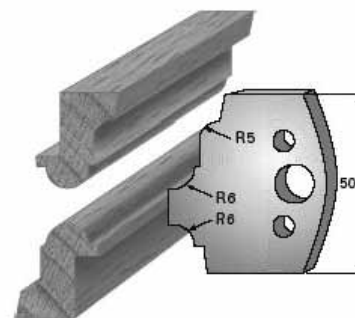

SP-Messer/Blade = Art.-Nr./Item no. 38542
HS-Messer/Blade = Art.-Nr./Item no. 36542
Abweiser/Deflector = Art.-Nr./Item no. 39542

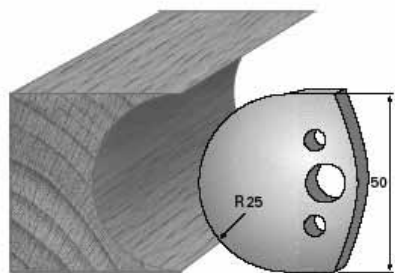

SP-Messer/Blade = Art.-Nr./Item no. 38543
HS-Messer/Blade = Art.-Nr./Item no. 36543
Abweiser/Deflector = Art.-Nr./Item no. 39543

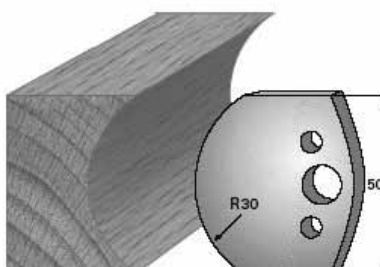

SP-Messer/Blade = Art.-Nr./Item no. 38544
HS-Messer/Blade = Art.-Nr./Item no. 36544
Abweiser/Deflector = Art.-Nr./Item no. 39544

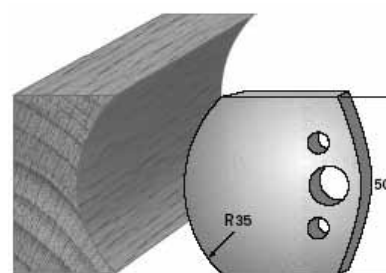

SP-Messer/Blade = Art.-Nr./Item no. 38545
HS-Messer/Blade = Art.-Nr./Item no. 36545
Abweiser/Deflector = Art.-Nr./Item no. 39545

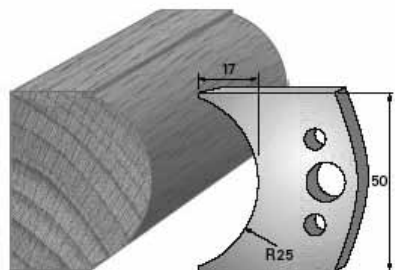

SP-Messer/Blade = Art.-Nr./Item no. 38546
HS-Messer/Blade = Art.-Nr./Item no. 36546
Abweiser/Deflector = Art.-Nr./Item no. 39546

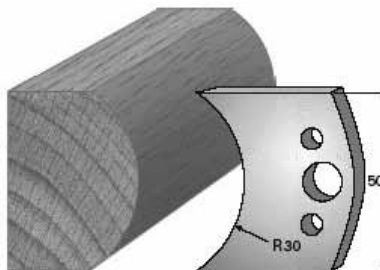

SP-Messer/Blade = Art.-Nr./Item no. 38547
HS-Messer/Blade = Art.-Nr./Item no. 36547
Abweiser/Deflector = Art.-Nr./Item no. 39547

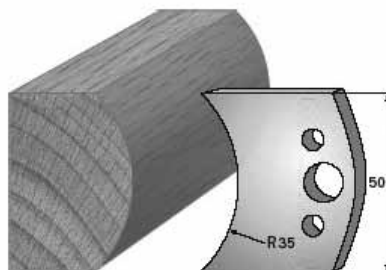

SP-Messer/Blade = Art.-Nr./Item no. 38548
HS-Messer/Blade = Art.-Nr./Item no. 36548
Abweiser/Deflector = Art.-Nr./Item no. 39548

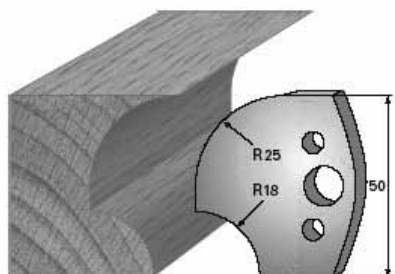

SP-Messer/Blade = Art.-Nr./Item no. 38549
HS-Messer/Blade = Art.-Nr./Item no. 36549
Abweiser/Deflector = Art.-Nr./Item no. 39549

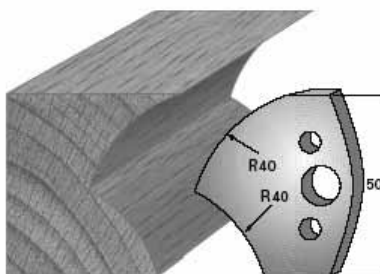

SP-Messer/Blade = Art.-Nr./Item no. 38550
HS-Messer/Blade = Art.-Nr./Item no. 36550
Abweiser/Deflector = Art.-Nr./Item no. 39550

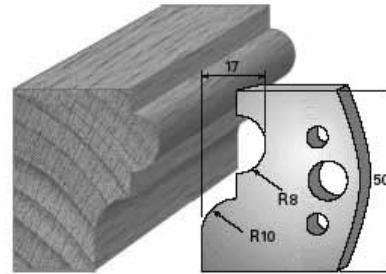

SP-Messer/Blade = Art.-Nr./Item no. 38551
HS-Messer/Blade = Art.-Nr./Item no. 36551
Abweiser/Deflector = Art.-Nr./Item no. 39551

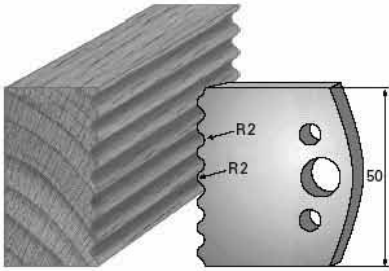

SP-Messer/Blade = Art.-Nr./Item no. 38552
 HS-Messer/Blade = Art.-Nr./Item no. 36552
 Abweiser/Deflector = Art.-Nr./Item no. 39552

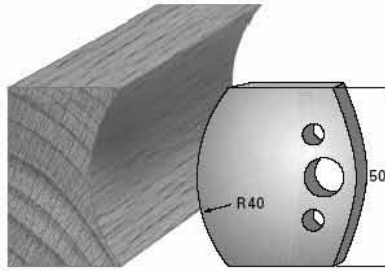

SP-Messer/Blade = Art.-Nr./Item no. 38553
 HS-Messer/Blade = Art.-Nr./Item no. 36553
 Abweiser/Deflector = Art.-Nr./Item no. 39553

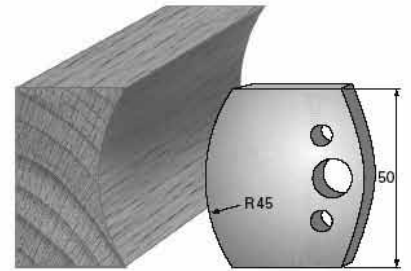

SP-Messer/Blade = Art.-Nr./Item no. 38554
 HS-Messer/Blade = Art.-Nr./Item no. 36554
 Abweiser/Deflector = Art.-Nr./Item no. 39554

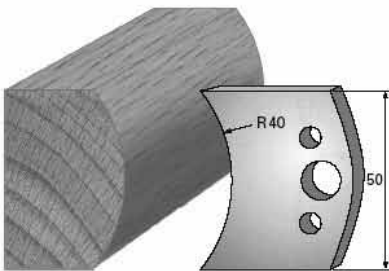

SP-Messer/Blade = Art.-Nr./Item no. 38555
 HS-Messer/Blade = Art.-Nr./Item no. 36555
 Abweiser/Deflector = Art.-Nr./Item no. 39555

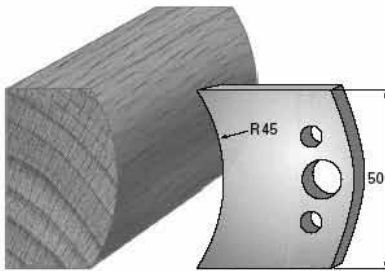

SP-Messer/Blade = Art.-Nr./Item no. 38556
 HS-Messer/Blade = Art.-Nr./Item no. 36556
 Abweiser/Deflector = Art.-Nr./Item no. 39556

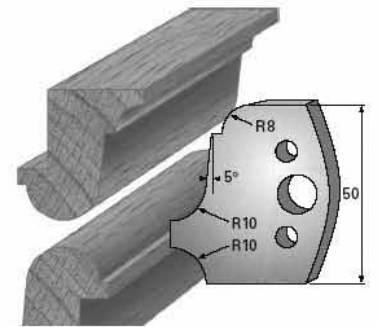

SP-Messer/Blade = Art.-Nr./Item no. 38557
 HS-Messer/Blade = Art.-Nr./Item no. 36557
 Abweiser/Deflector = Art.-Nr./Item no. 39557

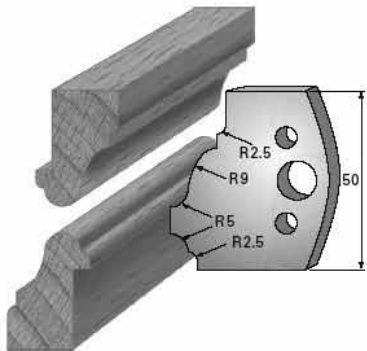

SP-Messer/Blade = Art.-Nr./Item no. 38558
 HS-Messer/Blade = Art.-Nr./Item no. 36558
 Abweiser/Deflector = Art.-Nr./Item no. 39558

**Neue Profile Nr. 532 - 540
 in 50 mm Breite**
**New profiles no. 532 - 540
 in 50 mm width**

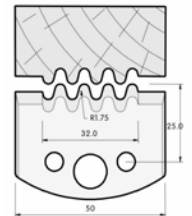

SP-Messer/Blade = Art.-Nr./Item no. 38532
 HS-Messer/Blade = Art.-Nr./Item no. 36532
 Abweiser/Deflector = Art.-Nr./Item no. 39532

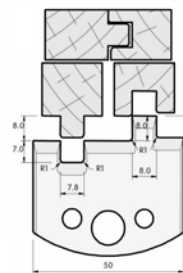

SP-Messer/Blade = Art.-Nr./Item no. 38533
 HS-Messer/Blade = Art.-Nr./Item no. 36533
 Abweiser/Deflector = Art.-Nr./Item no. 39533

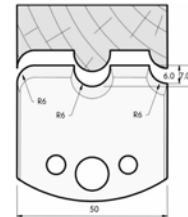

SP-Messer/Blade = Art.-Nr./Item no. 38534
 HS-Messer/Blade = Art.-Nr./Item no. 36534
 Abweiser/Deflector = Art.-Nr./Item no. 39534

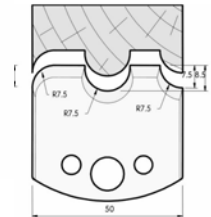

SP-Messer/Blade = Art.-Nr./Item no. 38535
 HS-Messer/Blade = Art.-Nr./Item no. 36535
 Abweiser/Deflector = Art.-Nr./Item no. 39535

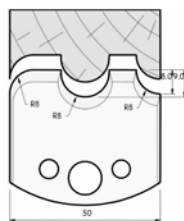

SP-Messer/Blade = Art.-Nr./Item no. 38536
 HS-Messer/Blade = Art.-Nr./Item no. 36536
 Abweiser/Deflector = Art.-Nr./Item no. 39536

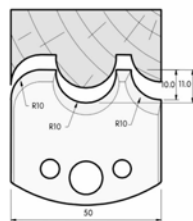

SP-Messer/Blade = Art.-Nr./Item no. 38537
 HS-Messer/Blade = Art.-Nr./Item no. 36537
 Abweiser/Deflector = Art.-Nr./Item no. 39537

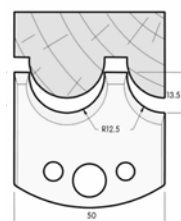

SP-Messer/Blade = Art.-Nr./Item no. 38538
 HS-Messer/Blade = Art.-Nr./Item no. 36538
 Abweiser/Deflector = Art.-Nr./Item no. 39538

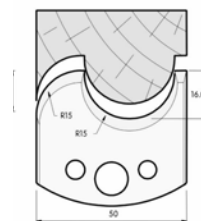

SP-Messer/Blade = Art.-Nr./Item no. 38539
 HS-Messer/Blade = Art.-Nr./Item no. 36539
 Abweiser/Deflector = Art.-Nr./Item no. 39539

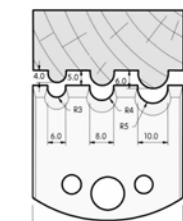

SP-Messer/Blade = Art.-Nr./Item no. 38540
 HS-Messer/Blade = Art.-Nr./Item no. 36540
 Abweiser/Deflector = Art.-Nr./Item no. 39540

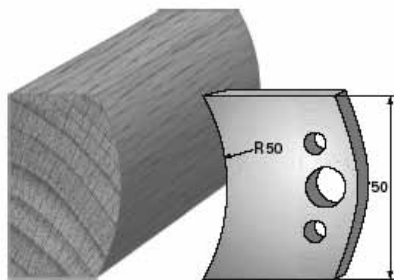

SP-Messer/Blade = Art.-Nr./Item no. 38559
HS-Messer/Blade = Art.-Nr./Item no. 36559
Abweiser/Deflector = Art.-Nr./Item no. 39559

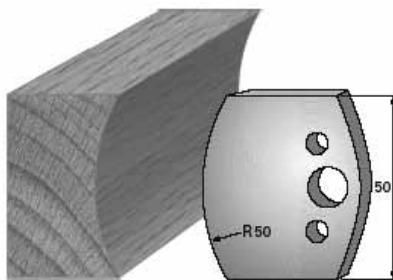

SP-Messer/Blade = Art.-Nr./Item no. 38560
HS-Messer/Blade = Art.-Nr./Item no. 36560
Abweiser/Deflector = Art.-Nr./Item no. 39560

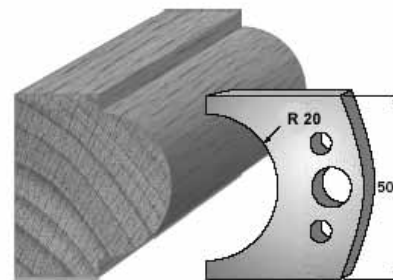

SP-Messer/Blade = Art.-Nr./Item no. 38561
HS-Messer/Blade = Art.-Nr./Item no. 36561
Abweiser/Deflector = Art.-Nr./Item no. 39561

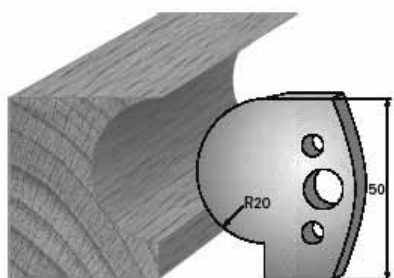

SP-Messer/Blade = Art.-Nr./Item no. 38562
HS-Messer/Blade = Art.-Nr./Item no. 36562
Abweiser/Deflector = Art.-Nr./Item no. 39562

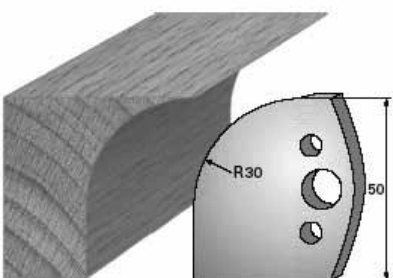

SP-Messer/Blade = Art.-Nr./Item no. 38563
HS-Messer/Blade = Art.-Nr./Item no. 36563
Abweiser/Deflector = Art.-Nr./Item no. 39563

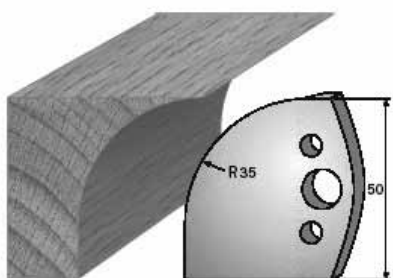

SP-Messer/Blade = Art.-Nr./Item no. 38564
HS-Messer/Blade = Art.-Nr./Item no. 36564
Abweiser/Deflector = Art.-Nr./Item no. 39564

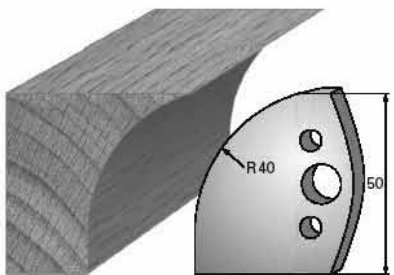

SP-Messer/Blade = Art.-Nr./Item no. 38565
HS-Messer/Blade = Art.-Nr./Item no. 36565
Abweiser/Deflector = Art.-Nr./Item no. 39565

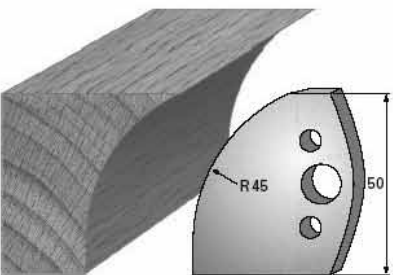

SP-Messer/Blade = Art.-Nr./Item no. 38566
HS-Messer/Blade = Art.-Nr./Item no. 36566
Abweiser/Deflector = Art.-Nr./Item no. 39566

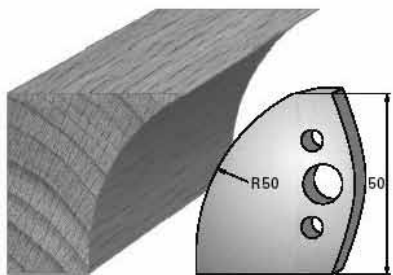

SP-Messer/Blade = Art.-Nr./Item no. 38567
HS-Messer/Blade = Art.-Nr./Item no. 36567
Abweiser/Deflector = Art.-Nr./Item no. 39567

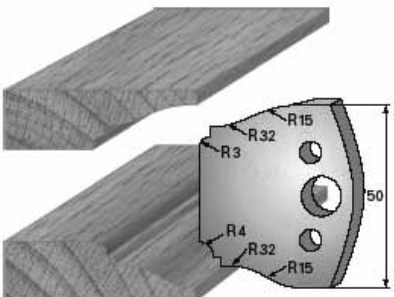

SP-Messer/Blade = Art.-Nr./Item no. 38568
HS-Messer/Blade = Art.-Nr./Item no. 36568
Abweiser/Deflector = Art.-Nr./Item no. 39568

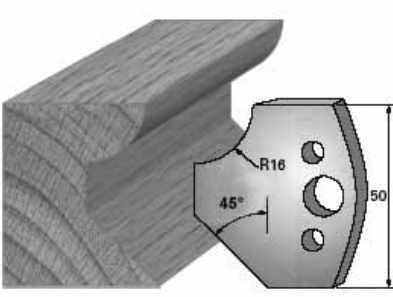

SP-Messer/Blade = Art.-Nr./Item no. 38569
HS-Messer/Blade = Art.-Nr./Item no. 36569
Abweiser/Deflector = Art.-Nr./Item no. 39569

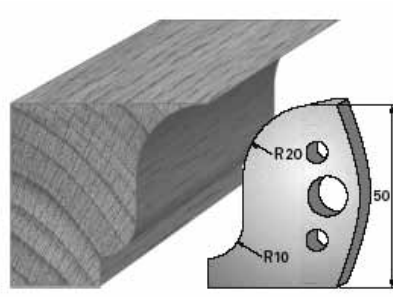

SP-Messer/Blade = Art.-Nr./Item no. 38570
HS-Messer/Blade = Art.-Nr./Item no. 36570
Abweiser/Deflector = Art.-Nr./Item no. 39570

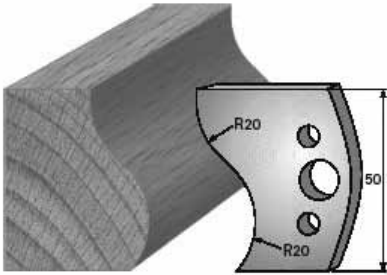

SP-Messer/Blade = Art.-Nr./Item no. 38571
 HS-Messer/Blade = Art.-Nr./Item no. 36571
 Abweiser/Deflector = Art.-Nr./Item no. 39571

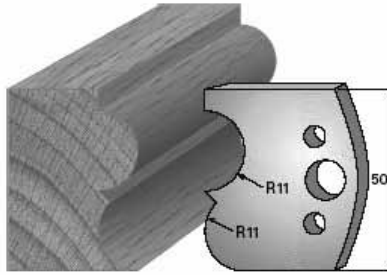

SP-Messer/Blade = Art.-Nr./Item no. 38572
 HS-Messer/Blade = Art.-Nr./Item no. 36572
 Abweiser/Deflector = Art.-Nr./Item no. 39572

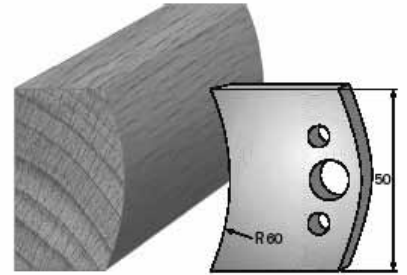

SP-Messer/Blade = Art.-Nr./Item no. 38573
 HS-Messer/Blade = Art.-Nr./Item no. 36573
 Abweiser/Deflector = Art.-Nr./Item no. 39573

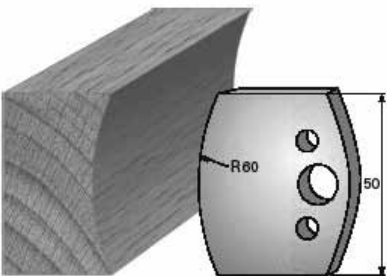

SP-Messer/Blade = Art.-Nr./Item no. 38574
 HS-Messer/Blade = Art.-Nr./Item no. 36574
 Abweiser/Deflector = Art.-Nr./Item no. 39574

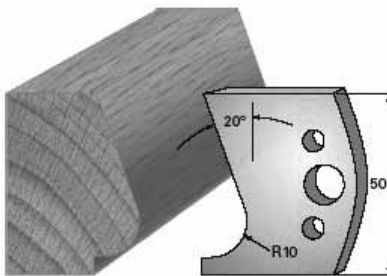

SP-Messer/Blade = Art.-Nr./Item no. 38575
 HS-Messer/Blade = Art.-Nr./Item no. 36575
 Abweiser/Deflector = Art.-Nr./Item no. 39575

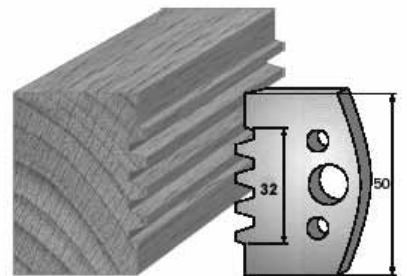

SP-Messer/Blade = Art.-Nr./Item no. 38576
 HS-Messer/Blade = Art.-Nr./Item no. 36576
 Abweiser/Deflector = Art.-Nr./Item no. 39576

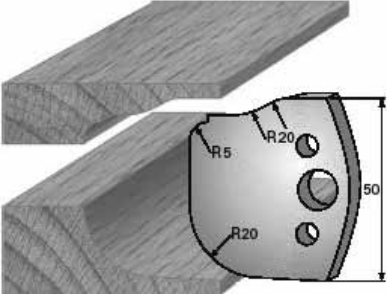

SP-Messer/Blade = Art.-Nr./Item no. 38577
 HS-Messer/Blade = Art.-Nr./Item no. 36577
 Abweiser/Deflector = Art.-Nr./Item no. 39577

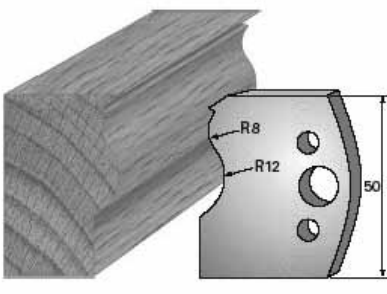

SP-Messer/Blade = Art.-Nr./Item no. 38578
 HS-Messer/Blade = Art.-Nr./Item no. 36578
 Abweiser/Deflector = Art.-Nr./Item no. 39578

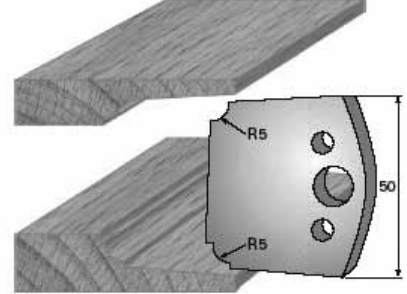

SP-Messer/Blade = Art.-Nr./Item no. 38579
 HS-Messer/Blade = Art.-Nr./Item no. 36579
 Abweiser/Deflector = Art.-Nr./Item no. 39579

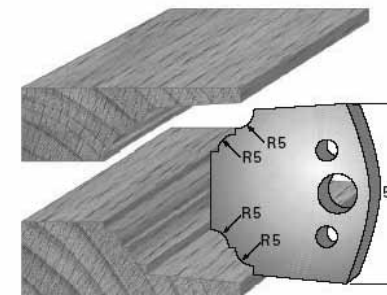

SP-Messer/Blade = Art.-Nr./Item no. 38580
 HS-Messer/Blade = Art.-Nr./Item no. 36580
 Abweiser/Deflector = Art.-Nr./Item no. 39580

UNIVERSAL-Großprofiler-System

für Profilmesser 60/80 x 5,5 mm

UNI large profiler system

for profiling blades 60/80 x 5,5 mm



Ausführung:

Werkzeugkörper aus Stahl, spandickenbegrenzt, rückschlagarm, vorzugsweise für Handvorschubarbeiten. Formschlüssige Messer- und Abweiserbefestigung auf konstanten Flugkreis.

Profilmesser aus **SP-Stahl** (nur 60 mm) und **HS-Stahl**, seitlich hinterschleifen lieferbar!

Max. Profiltiefe 27 mm

Design:

Tool made from steel, chip-thickness limitation, reduced recoil, preferably for manual feed. Positive blade and deflector form fastening with constant cutting circle.

*Profiling blades made of **special steel** (only 60 mm) and **high-speed steel**, laterally reliefground.*

Max. profile depth 27 mm

Anwendung:

Vorwiegend zum Profilieren von Weich- und Harthölzern (Vollholz unverleimt).

Profilmesser mit den jeweils passenden Abweisern sind stets paarweise einzusetzen.

Application:

Preferably for soft- and hardwood (unglued solid wood).

Profiling blades and the corresponding deflectors to be used in pairs.

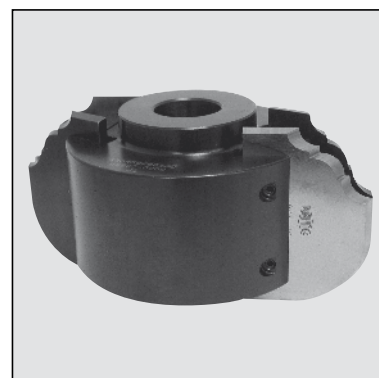

Art.-Nr./Item no. 3930



Art.-Nr./Item no. 3924

Abb. der lieferbaren Profile siehe folgende Seiten.

Illustrations of the available profiles, see following pages.

Artikel-Nr. Item no.	Bezeichnung Description	n/min ⁻¹	EURO Stück/pce
3920	SOLO-Messerkopf 110 x 60 x 30 mm Z 2 (ohne Messerbestückung) SOLO head 110 x 60 x 30 mm Z 2 (without blades)	4.000 - 6.000	
3921	SOLO-Messerkopf 110 x 60 x 40 mm Z 2 (ohne Messerbestückung) SOLO head 110 x 60 x 40 mm Z 2 (without blades)	4.000 - 6.000	
3930	SOLO-Messerkopf 110 x 60/80 x 30 mm Z 2 (ohne Messerbestückung) SOLO head 110 x 60/80 x 30 mm Z 2 (without blades)	4.200 - 6.000	
3931	SOLO-Messerkopf 110 x 60/80 x 40 mm Z 2 (ohne Messerbestückung) SOLO head 110 x 60/80 x 40 mm Z 2 (without blades)	4.200 - 6.000	
3924	UNI-Großprofiler-Set kpl. m. 4 Profil- und Abweiserpaaren (SP-Stahl) (Profil 60004; 60008; 60011; 60021) inkl. Holzkassette UNI large profiler set complete with 4 profile and deflector pairs (profiles no. 60004; 60008; 60011; 60021) incl. wooden box		

Artikel-Nr. Item no.	Bezeichnung Description	EURO Stück/pce
60000 - 60021	SP-Stahl Profilmesser 60 x 5,5 mm/special steel profiling blade 60 x 5,5 mm	
62000 - 62021	HS-Stahl Profilmesser 60 x 5,5 mm/high-speed steel profiling blade 60 x 5,5 mm	
61000A - 61021A	Abweiser für dto. 58 x 5,3 mm/deflector for ditto 58 x 5,3 mm	
62500	HS-Blankett 60 x 5,5 mm/high-speed steel blank 60 x 5,5 mm	
61500	Abweiser Blankett/deflector blank	
80001 - 80004	HS-Stahl Profilmesser 80 x 5,5 mm/high-speed steel profiling blade 80 x 5,5 mm	
81001 - 81004	Abweiser für dto. 78 x 5,3 mm/deflector for ditto 78 x 5,3 mm	
80500	HS-Blankett 80 x 5,5 mm/high-speed steel blank 80 x 5,5 mm	
81500	Abweiser Blankett 78 x 5,3 mm/deflector blank 78 x 5,3 mm	

- Sonderprofil-Preisgruppen siehe Seite 6.32
- Schärpreise für Standard- und Sonderprofile siehe Seite 6.33
- Abgabe der Standard- und Sonderprofile immer satzweise.

- Price categories for special profiles: please see page 6.32
- Prices for sharpening/standard and special profiles: please see page 6.33
- All standard and special profiles only available in pairs.

Weitere Ersatzteile (Schrauben, Spankeile usw.) siehe Seite 14.5 - 14.9
More Replacement parts (screws, wedges etc.) see page 14.5 - 14.9

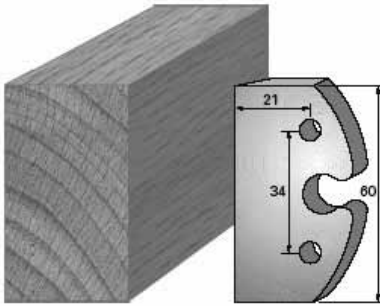

SP-Messer/Blade = Art.-Nr./Item no. 60000
 HS-Messer/Blade = Art.-Nr./Item no. 62000
 Abweiser/Deflector = Art.-Nr./Item no. 61000A

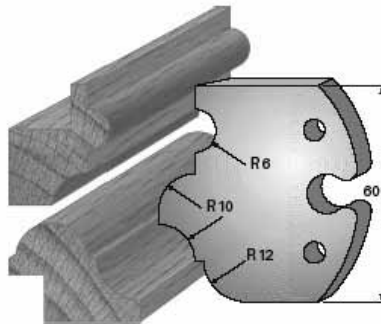

SP-Messer/Blade = Art.-Nr./Item no. 60001
 HS-Messer/Blade = Art.-Nr./Item no. 62001
 Abweiser/Deflector = Art.-Nr./Item no. 61001A

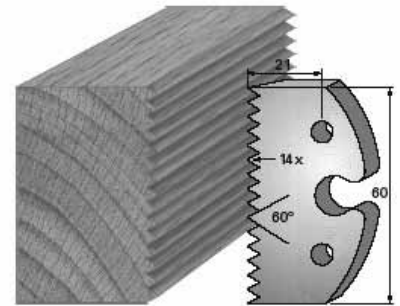

SP-Messer/Blade = Art.-Nr./Item no. 60003
 HS-Messer/Blade = Art.-Nr./Item no. 62003
 Abweiser/Deflector = Art.-Nr./Item no. 61003A

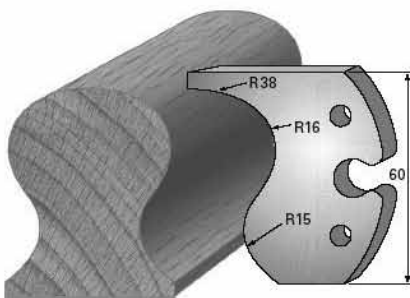

SP-Messer/Blade = Art.-Nr./Item no. 60004
 HS-Messer/Blade = Art.-Nr./Item no. 62004
 Abweiser/Deflector = Art.-Nr./Item no. 61004A

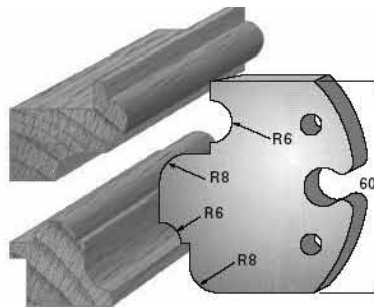

SP-Messer/Blade = Art.-Nr./Item no. 60006
 HS-Messer/Blade = Art.-Nr./Item no. 62006
 Abweiser/Deflector = Art.-Nr./Item no. 61006A

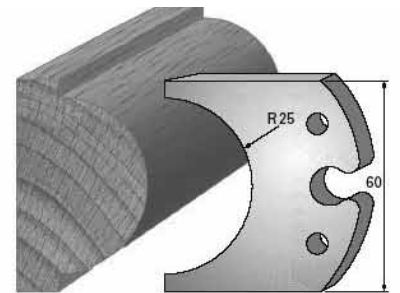

SP-Messer/Blade = Art.-Nr./Item no. 60008
 HS-Messer/Blade = Art.-Nr./Item no. 62008
 Abweiser/Deflector = Art.-Nr./Item no. 61008A

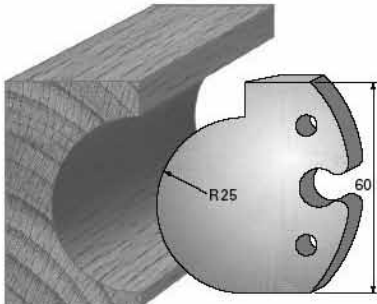

SP-Messer/Blade = Art.-Nr./Item no. 60009
 HS-Messer/Blade = Art.-Nr./Item no. 62009
 Abweiser/Deflector = Art.-Nr./Item no. 61009A

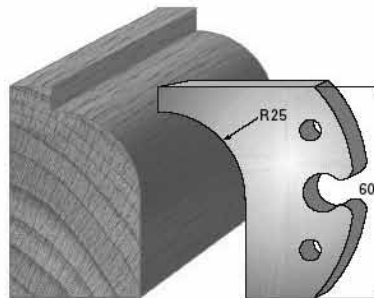

SP-Messer/Blade = Art.-Nr./Item no. 60010
 HS-Messer/Blade = Art.-Nr./Item no. 62010
 Abweiser/Deflector = Art.-Nr./Item no. 61010A

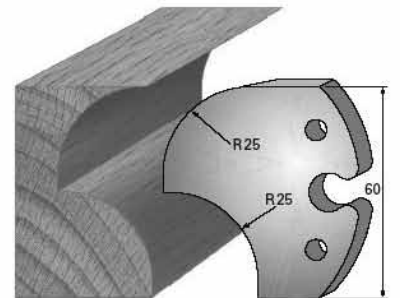

SP-Messer/Blade = Art.-Nr./Item no. 60011
 HS-Messer/Blade = Art.-Nr./Item no. 62011
 Abweiser/Deflector = Art.-Nr./Item no. 61011A

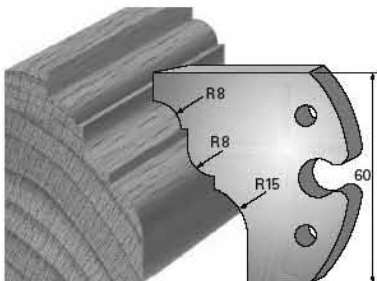

SP-Messer/Blade = Art.-Nr./Item no. 60012
 HS-Messer/Blade = Art.-Nr./Item no. 62012
 Abweiser/Deflector = Art.-Nr./Item no. 61012A

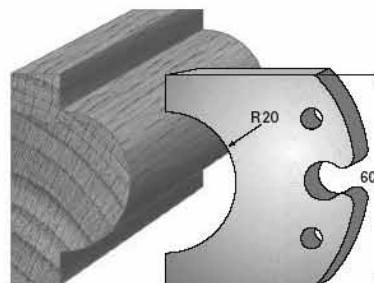

SP-Messer/Blade = Art.-Nr./Item no. 60016
 HS-Messer/Blade = Art.-Nr./Item no. 62016
 Abweiser/Deflector = Art.-Nr./Item no. 61016A

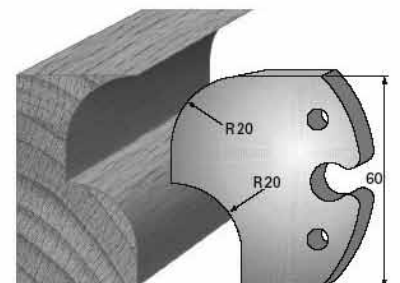

SP-Messer/Blade = Art.-Nr./Item no. 60019
 HS-Messer/Blade = Art.-Nr./Item no. 62019
 Abweiser/Deflector = Art.-Nr./Item no. 61019A

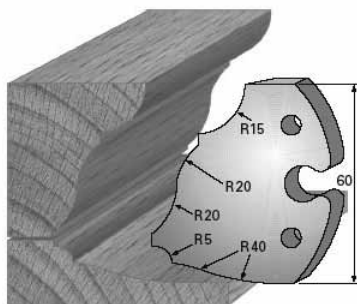

SP-Messer/Blade = Art.-Nr./Item no. 60020
HS-Messer/Blade = Art.-Nr./Item no. 62020
Abweiser/Deflector = Art.-Nr./Item no. 61020A

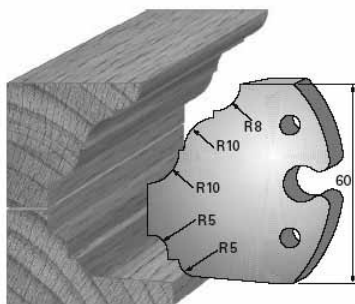

SP-Messer/Blade = Art.-Nr./Item no. 60021
HS-Messer/Blade = Art.-Nr./Item no. 62021
Abweiser/Deflector = Art.-Nr./Item no. 61021A

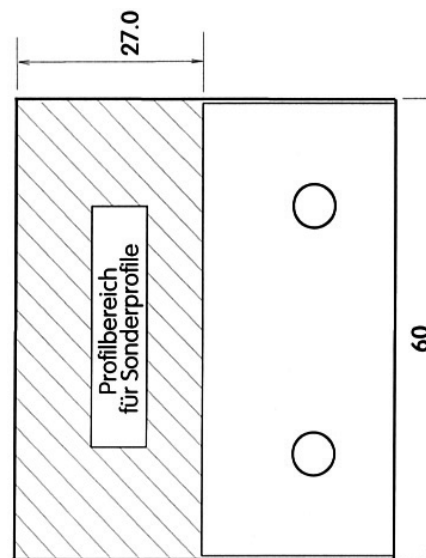

HS-Messer/Blade = Art.-Nr./Item no. 62500
Abweiser Blankett/Deflector Blank = Art.-Nr./Item no. 61500

Profilmesser 80 x 5,5 mm HS-Stahl - passend für SOLO-Profilmesserkopf Art.Nr. 3930
Profiling blades 80 x 5,5 mm from high-speed-steel - for SOLO head Item no. 3930

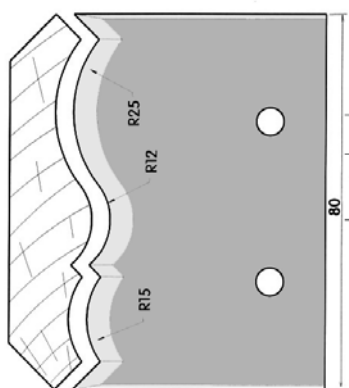

HS-Messer/Blade = Art.-Nr./Item no. 80001
Abweiser/Deflector = Art.-Nr./Item no. 81001

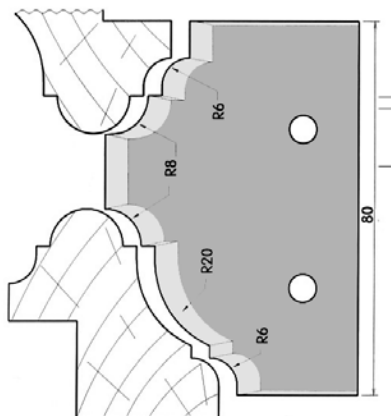

HS-Messer/Blade = Art.-Nr./Item no. 80002
Abweiser/Deflector = Art.-Nr./Item no. 81002

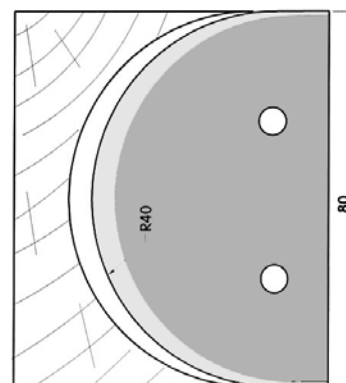

HS-Messer/Blade = Art.-Nr./Item no. 80003
Abweiser/Deflector = Art.-Nr./Item no. 81003

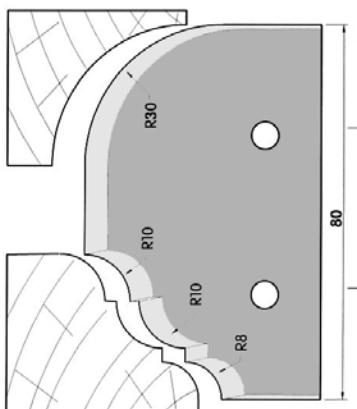

HS-Messer/Blade = Art.-Nr./Item no. 80004
Abweiser/Deflector = Art.-Nr./Item no. 81004

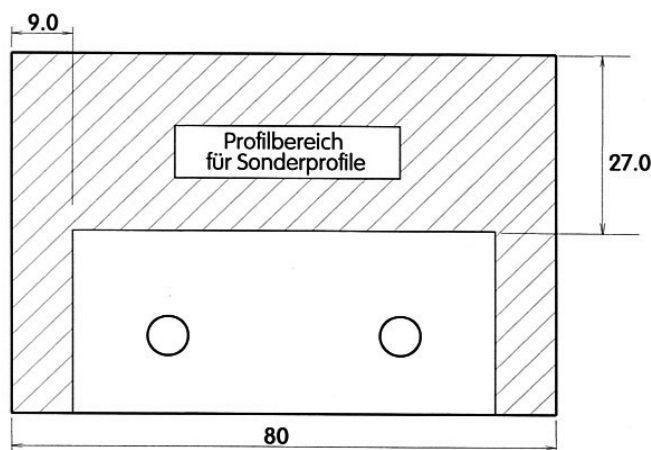

HS-Messer/Blade = Art.-Nr./Item no. 80500
Abweiser Blankett/Deflector Blank = Art.-Nr./Item no. 81500

Profilmesserkopf - rückenverzahnt Head for profiling blades - serrated



Ausführung:

Sicherheits-Profilmesserkopf mit exakt formschlüssiger Messereinspannung.

Ohne Messerbestückung !

Verzahnung am Messerrücken und in der Messerauflage im Messerkopf.

Werkzeugkörper aus Stahl, für den Einsatz von 2 oder 4 Profilmesser mit 8 oder 10 mm Stärke mit Verzahnung am Messerrücken.

Beim Einsatz von nur 2 Profilmesser müssen die 2 gegenüberliegenden Einbaustellen durch 2 Blindstücke geschlossen werden

Anwendung:

Zum Fräsen von Massivhölzern in Längsrichtung mit Profilmesser in HS-Qualität.

Hartmetallbestückte Profilmesser für den Einsatz bei Harthölzern.

Design:

Security head for profiling blades with serrated back. With exact positive-locking clamping system.

Without blades !

Cutter head and blades are serrated.

Tool made from steel, for the use of 2 or 4 profile blades of 8 or 10 mm with serrated back.

When using only 2 profile blades, the opposite installation positions must be closed with blind pieces.

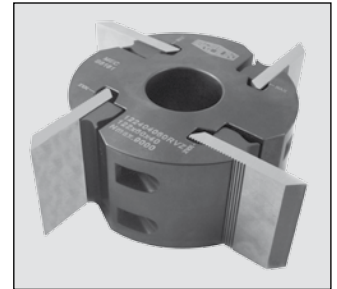

Art.-Nr./Item no.
122404060RVZ

Application:

For cutting solid woods in longitudinal direction with profile blades in HS quality.

Tungsten carbide profile blades usable for hardwood.

Artikel-Nr. Item no.	D/D mm	B/W mm	d/b mm	d/b max. mm	Z	n/min ⁻¹ max.	EURO Stück/pce
122 404 040 RVZ	122	40	40	40	4	9.000	
122 404 060 RVZ	122	60	40	40	4	9.000	
122 404 080 RVZ	122	80	40	40	4	9.000	
122 404 100 RVZ	122	100	40	40	4	9.000	
122 404 120 RVZ	122	120	40	40	4	9.000	
122 404 130 RVZ	122	130	40	40	4	9.000	
122 404 150 RVZ	122	150	40	40	4	9.000	
122 404 180 RVZ	122	180	40	40	4	9.000	
122 404 230 RVZ	122	230	40	40	4	9.000	
122 404 240 RVZ	122	240	40	40	4	9.000	
137 404 060 RVZ	137	60	40	50	4	8.700	
137 404 080 RVZ	137	80	40	50	4	8.700	
137 404 100 RVZ	137	100	40	50	4	8.700	
137 404 130 RVZ	137	130	40	50	4	8.700	
137 404 180 RVZ	137	180	40	50	4	8.700	
137 404 230 RVZ	137	230	40	50	4	8.700	

Sonderleistungen wie z. B. andere Bohrungen - auf Anfrage.
Andere Abmessungen und Ausführungen - auf Anfrage.

*Extras such as different bores upon request.
Other dimensions and designs upon request.*

Blanketten mit 60°-Rückenverzahnung HS-Qualität Serrated cutter 60° blanks in HS-quality

Ausführung:

Präzisions-Blanketten mit 60° „Weinig-Rückenverzahnung“ und Fase, stirnseitig exakt winkelig geschnitten, gewichtsgleich und allseitig plangeschliffen.

Design:

Precision blanks with 60° Weinig serrated back and chamfer, cut angular at the gable ends, same weight and face grinded.

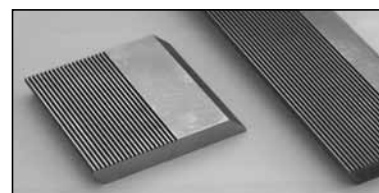

HS-Qualität die bewährte DMO5-Qualität

HS quality the proved DMO5 quality

Anwendung:

Für Profil- und Hydro-Messerköpfe zur Bearbeitung von Hart- und Weichhölzern.

Application:

For profile- and hydro cutterheads for cutting hard- and softwood.

Artikel-Nr. Item no.	Breite mm width mm	Höhe mm height mm	Stärke mm thickness mm	EURO Stück/pce
9804058	40	50	8	
9805058	50	50	8	
9806058	60	50	8	
9808058	80	50	8	
9810058	100	50	8	
9813058	130	50	8	
9815058	150	50	8	
9818058	180	50	8	
9823058	230	50	8	
9865058	650	50	8	
9804068	40	60	8	
9805068	50	60	8	
9806068	60	60	8	
9808068	80	60	8	
9810068	100	60	8	
9813068	130	60	8	
9815068	150	60	8	
9818068	180	60	8	
9823068	230	60	8	
9865068	650	60	8	
9804078	40	70	8	
9805078	50	70	8	
9806078	60	70	8	
9808078	80	70	8	
9810078	100	70	8	
9813078	130	70	8	
9815078	150	70	8	
9818078	180	70	8	
9823078	230	70	8	
9826078	260	70	8	
9865078	650	70	8	

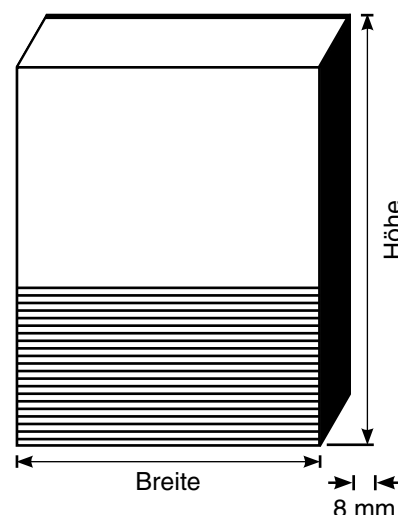

Höhe mm height mm	T max.= max. Profiltiefe mm T max.= max. profile depth mm
50	20
60	25
70	30

RVZ-Blanketten in HW-Qualität auf Anfrage!

Serrated-blanks in TC-quality on request!

Preise für Profilierung der Blanketts auf Anfrage!

Prices for the blank profiling on request!

Andere Abmessungen und Ausführungen - auf Anfrage.

Verpackungseinheit: 2 Stück

Other dimensions and designs upon request.

Packing quantities: 2 pcs

UNI-Profilmesser Blanketts + Sonderprofile HS

UNI profiling blades blanks + special profiles high-speed steel

Bezeichnung Description	Messer/Blade		Abweiser/Deflector		kpl. Satz**/cpl. set***	
	Art.-Nr. Item no.	EURO Stück/pce	Art.-Nr. Item no.	EURO Stück/pce	Art.-Nr. Item no.	EURO Stück/pce

UNI-Profil 40 x 4 mm/UNI profiles 40 x 4 mm

passend für Art.-Nr./suitable for items no. 3500; 3501; 3502; 3503; 3504; 3505; 3910; 3911

Blanketts - HS/Blanks - high-speed steel	36900		37999			
Blanketts - SP/Blanks - special steel	36901		37999			

SONDERPROFILE (in HS-Qualität) - max. Profiltiefe = 17 mm/SPECIAL PROFILES (HS-quality) - max. profile depth = 17 mm

Profilgruppe I*/Profile category I*					38300	
Profilgruppe II*/Profile category II*					38301	
Profilgruppe III*/Profile category III*					38302	

nur Messer bei Nachbestellung/pro Paar/only blades (repeat order)/pair

Profilgruppe I*/Profile category I*	36910					
Profilgruppe II*/Profile category II*	36920					
Profilgruppe III*/Profile category III*	36930					

UNI-Profil 50 x 4 mm/UNI profiles 50 x 4 mm

passend für Art.-Nr./suitable for items no. 3910; 3911

Blanketts - HS/Blanks - high-speed steel	36903		37306			
--	-------	--	-------	--	--	--

SONDERPROFILE (in HS-Qualität) - max. Profiltiefe = 17 mm/SPECIAL PROFILES (HS-quality) - max. profile depth = 17 mm

Profilgruppe I*/Profile category I*					38307	
Profilgruppe II*/Profile category II*					38308	
Profilgruppe III*/Profile category III*					38309	

nur Messer bei Nachbestellung/pro Paar/only blades (repeat order)/pair

Profilgruppe I*/Profile category I*	36911					
Profilgruppe II*/Profile category II*	36921					
Profilgruppe III*/Profile category III*	36931					

Großprofilmesser 60 x 5,5 mm/Large profile blades 60 x 5,5 mm

passend für Art.-Nr./suitable for items no. 3920; 3921; 3930; 3931

Blanketts - HS/Blanks - high-speed steel	62500		61500			
--	-------	--	-------	--	--	--

SONDERPROFILE (in HS-Qualität) - max. Profiltiefe = 27 mm/SPECIAL PROFILES (HS-quality) - max. profile depth = 27 mm

Profilgruppe I*/Profile category I*					38310	
Profilgruppe II*/Profile category II*					38311	
Profilgruppe III*/Profile category III*					38312	

nur Messer bei Nachbestellung/pro Paar/only blades (repeat order)/pair

Profilgruppe I*/Profile category I*	36912					
Profilgruppe II*/Profile category II*	36922					
Profilgruppe III*/Profile category III*	36932					

Großprofilmesser 80 x 5,5 mm/Large profile blades 80 x 5,5 mm

passend für Art.-Nr./suitable for items no. 3930; 3931

Blanketts/Blanks 80 x 5,5 mm	80500		81500			
------------------------------	-------	--	-------	--	--	--

SONDERPROFILE (in HS-Qualität) - max. Profiltiefe = 27 mm/SPECIAL PROFILES (HS-quality) - max. profile depth = 27 mm

Profilgruppe I*/Profile category I*					38320	
Profilgruppe II*/Profile category II*					38321	
Profilgruppe III*/Profile category III*					38322	

nur Messer bei Nachbestellung/pro Paar/only blades (repeat order)/pair

Profilgruppe I*/Profile category I*	36914					
Profilgruppe II*/Profile category II*	36924					
Profilgruppe III*/Profile category III*	36934					

* Profilgruppe I - III siehe separate Aufstellung nächste Seite

** kpl. Satz = 2 Messer/2 Abweiser

* For profile categories I - III, see list on the next page

** complete set = 2 blades/2 deflectors

Schärfpreise für UNI-Profilmesser, Sonderprofile und Abweiser

Prices for sharpening UNI profiling blades, special profiles and deflectors

Ausführung Description	Werkstoff Material	Messer/Blade		Abweiser/Deflector	
		Art.-Nr. Item no.	EURO Stück/pce	Art.-Nr. Item no.	EURO Stück/pce

UNI-Profile 40 mm/UNI profiles 40 mm

Profilgruppe I*/Profile category I*	HS/SP/High-speed steel/special steel	363001	373001
Profilgruppe II*/Profile category II*	HS/SP/High-speed steel/special steel	363011	373011
Profilgruppe III*/Profile category III*	HS/SP/High-speed steel/special steel	363021	373021

UNI-Profile 50 mm/UNI profiles 50 mm

Profilgruppe I*/Profile category I*	HS/SP/High-speed steel/special steel	363071	373071
Profilgruppe II*/Profile category II*	HS/SP/High-speed steel/special steel	363081	373081
Profilgruppe III*/Profile category III*	HS/SP/High-speed steel/special steel	363091	373091

Großprofile 60 + 59/64 mm/Large profiles 60 + 59/64 mm

Profilgruppe I*/Profile category I*	HS/SP/High-speed steel/special steel	363141	373141
Profilgruppe II*/Profile category II*	HS/SP/High-speed steel/special steel	363151	373151
Profilgruppe III*/Profile category III*	HS/SP/High-speed steel/special steel	363161	373161

Großprofile 80 mm/Large profiles 80 mm

Profilgruppe I*/Profile category I*	HS/High-speed steel	363241	373241
Profilgruppe II*/Profile category II*	HS/High-speed steel	363251	373251
Profilgruppe III*/Profile category III*	HS/High-speed steel	363261	373261

* Profilgruppe I - III siehe separate Aufstellung unten

* For profile categories I - III, see list below

Profilgruppeneinteilung/Profile categories

Profilgruppe I

einfache und einseitig in sich hinterschliffene Profile

Profile category I

simple profiles, relief-ground on one side

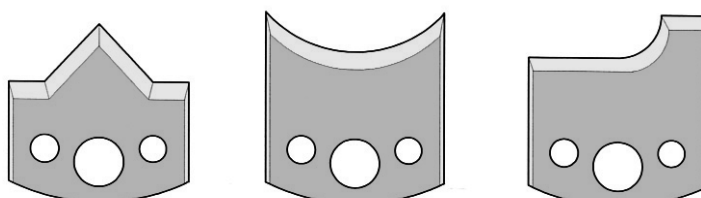

Profilgruppe II

komplizierte und beidseitig in sich hinterschliffene Profile

Profile category II

complex profiles, relief-ground on both sides

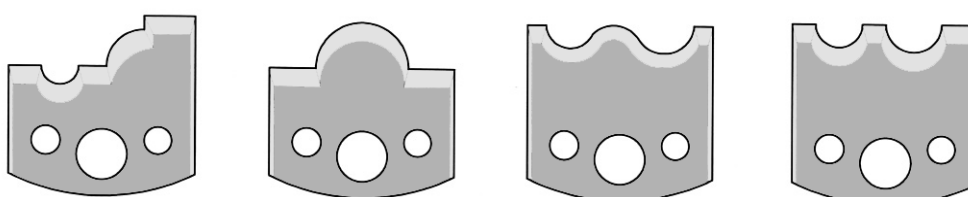

Profilgruppe III

in sich ineinander passende Profile und Konterprofile

Profile category III

Matching profiles and counter profiles

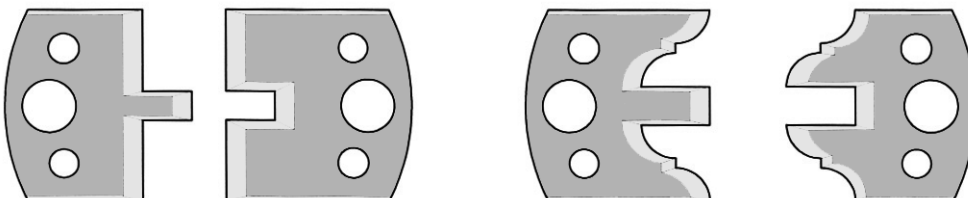

Drehschema für Fräser

Cutter rotating modes

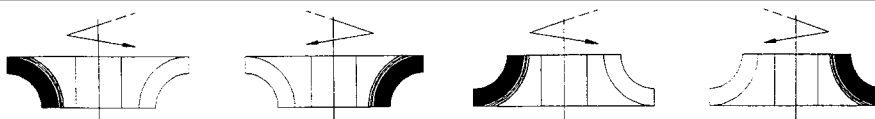

Normalschema 1 großer Ø
oben Rechtslauf
Mode 1 (standard) large Ø on
upper side, right-handed rotation

Drehschema 2 großer Ø
oben Linkslauf
Mode 2 large Ø on upper
side, left-handed rotation

Drehschema 3 großer Ø
unten Rechtslauf
Mode 3 large Ø on lower
side, right-handed rotation

Drehschema 4 großer Ø
unten Linkslauf
Mode 4 large Ø on lower
side, left-handed rotation

Notizen:/Notes:

